

ATech Training™

An ASE™ Certified Training Provider



Proud Member of

Training Managers Council
ATMC

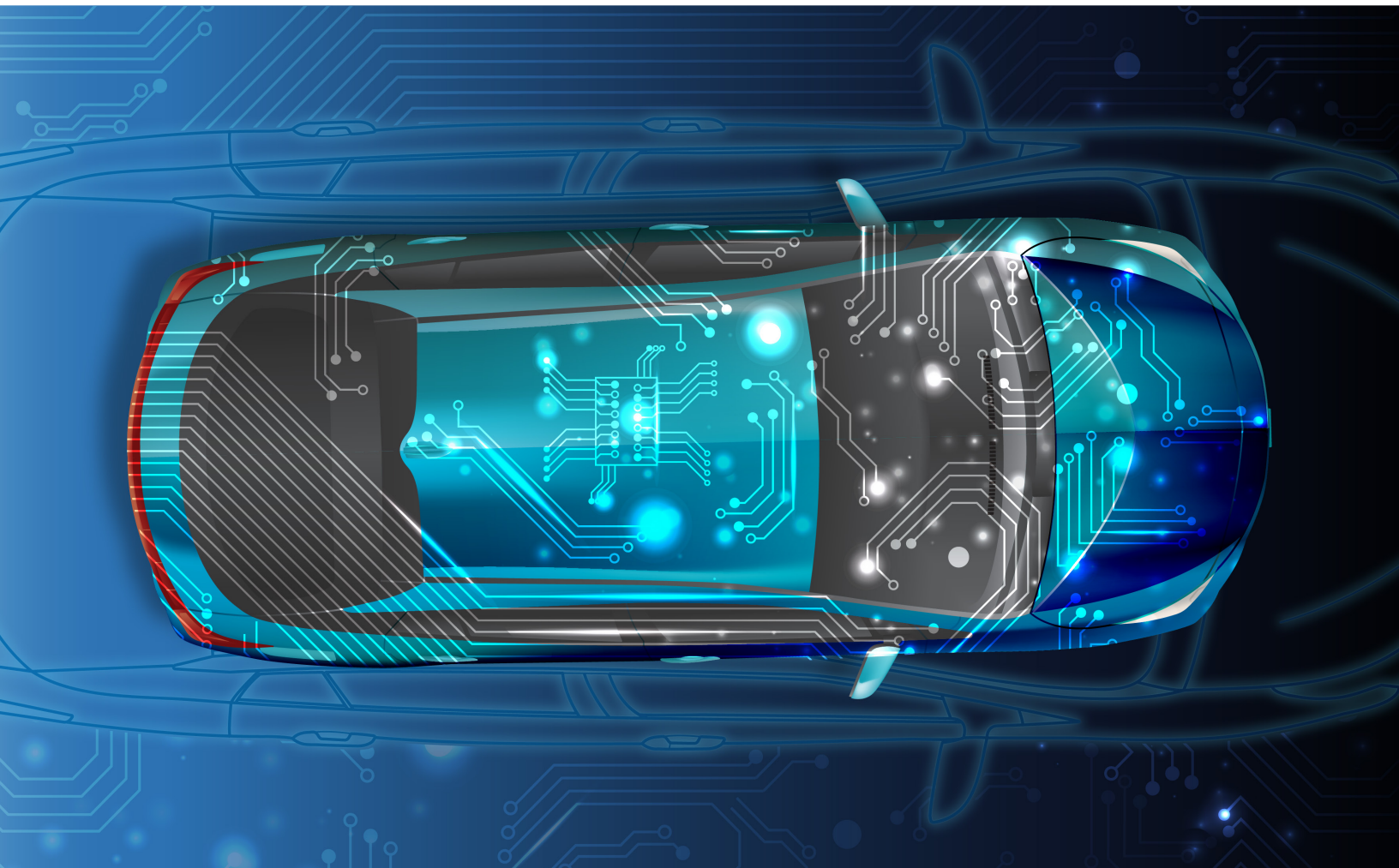

VOLUME
9

ATech Training, Inc.
A Veteran Owned and Operated American Company

Table of Contents

- ATech’s Free Products and Services.....6-7
- Automotive Classroom.....8-9
- Automotive Technology Lab.....10
- Stem Activities.....11

Automotive Systems

Pg. 12- 29

I. Air Bag System

- Supplemental Inflatable Restraint System Trainer - 1552.....12

II. Brakes

- Drum/Disc Brake Trainer (4 Wheel) - 400.....13
- Delco DBC7 ABS/TCS System Trainer - 1432.....13

III. Heating Ventilation and Air Conditioning (HVAC)

- Engine Cooling Fan System (J1850) Trainer - 310FJ.....14
- Fan Speed Control Trainer - 311.....14
- Blower Control System (J1850) Trainer - 320FJ.....15
- Air Conditioning with Automatic Climate Control (R1234yf) Trainer - 1352.....15
- Air Conditioning with Automatic Climate Control (R134A) Trainer - 1351.....16

IV. Smarter Car

- Starting System (CAN) Trainer - 811C.....17
- Charging System (CAN) Trainer - 812C.....18
- Lighting System (CAN) Trainer - 821C.....19
- Wiper/Washer System (CAN) Trainer - 830C.....20
- Power Window System (CAN) Trainer - 840C.....21
- Power Door Lock System (CAN) Trainer - 850C.....22
- Power Seat System (CAN) Trainer - 860C.....23
- Smarter Car- “Class under the Hood”.....24

V. Steering and Suspension

- Driveline Simulator - 250.....25
- Suspension and Steering System (Hydraulic) - 500.....26
- Suspension and Steering System (Electronic) - 500E.....27

VI. Transmissions and Transaxles

- Manual Transaxle Rebuild Trainer - 110.....28
- Electronic Automatic Transaxle Rebuild Trainer - 1210 FWD.....28
- Electronic Automatic Transmission Rebuild Trainer - 1220 RWD.....29

VII. Electrical/Electronic

- Electricity Trainer - 1810.....30
- Electronics Trainer -1820.....31
- Interactive Key Pad - 1802C.....32
- Electrical/Pulse Width Modulation/Fault Trainer - 2210.....33
- Applied Electrical Trainer - 4810.....34
- Electromechanical Trainer - 4820.....35
- Electrical Skill Development Trainer - 5810.....36
- Electrical Skill Development Troubleshooting Trainer - 5810TT.....37

IX. Manufacturer Specialized Electronic Trainers

- Caterpillar Fundamentals of Electrical Systems - 18002CAT.....38
- Honda Specialized Electronic Trainer - 18002H.....38
- John Deere Specialized Electronic Trainer - 18002JD.....38
- GM Specialized Electronic Trainer - 18002TR.....39
- GM Specialized Electronic Troubleshooting Trainer - 18002TT.....40

X. Submounts

- Optional Submounts.....41

Engine Performance

XI. Engine Performance

- Engine Performance Trainer - 650.....42
- Engine Performance Trainer Special - 650S.....43
- Bi-Fuel Engine Performance Trainer - 650BF.....44
- Engine Performance Troubleshooting - 3601.....45

XII. Engine Repair

- Engine Repair Trainer - 90.....46
- Engine Start Cart - 91.....46

XIII. Evaporative Emissions System

- Evaporative (EVAP) System Trainer - 640.....47

XIV. Fuel Pump/Injection

- Injector/Fuel Pump System Trainer - 670.....48

XV. Ignition System

- GM Direct Ignition System Trainer - 1711F.....49
- Ford Integrated Electronic Ignition System Trainer - 1792.....49
- GM Electronic Ignition System Trainer - 1772.....50

XVI. OBD II Trainer

- GM (J1850) OBD II System Trainer - 2652.....51
- GM (J1850) OBD II System Trainer (DRY) - 2652 (DRY).....51

XVII. Vehicle Technology Trainers

- Automotive Technology Trainer - 600.....52
- Intermittent Fault Box - 2112.....53

Electric Vehicle Technology

Pg. 54- 57

XVII. EV Trainer

- Electric Vehicle Trainer - 5820.....54

XVII. Vehicle Technology Trainers

- Vehicle Technology Trainer Nissan Leaf - 610N.....55
- Vehicle Technology Trainer Toyota Prius - 610T.....56

XVII. Cutaway

- Hybrid Powertrain Cutaway - 680S.....57

Diesel Technology

Pg. 58- 63

XVIII. Diesel Engine Performance

- Diesel Engine Performance Trainer - 650D.....58
- Diesel Technology Trainer - 650HD.....59

XIX. Diesel Technology Trainer

- Diesel Technology Trainer - 600D.....60

XX. Diesel BrakeS (Air Brake Systems)

- Tractor Air-Brake System Trainer - 6410.....61
- Trailer Air-Brake System Trainer - 6420.....61
- 3 Axle Air-Brake System Trainer - 6430.....62

XXI. Diesel Engine Repair

- Diesel Engine Repair Trainer - 90D.....63
- Diesel Engine Start Cart - 91D.....63

Computer-Based Instruction

Pg. 64- 73

- Classroom Management Program - CMP.....64
- Electricity Software - 1810SC.....65
- Electronics Software - 1820SC.....65
- Starter System Troubleshooting - 2815SC.....66

- Engine Performance Troubleshooting Trainer - 3601.....67
- Engine Control Fundamentals - 3610.....68
- Engine Controls System Operations - 3620.....68
- Engine Controls Diagnostic Fundamentals - 3630.....68
- Engine Control System Troubleshooting - 3631.....69-70
- General Motors S.E.T. Troubleshooting Trainer With CMP-18002TT.....71
- General Motors S.E.T. Virtual Trainer (Stage 1) - 18002VT1.....72-73
- General Motors S.E.T. Virtual Trainer (Stage 2) - 18002VT2.....72-73
- General Motors S.E.T. Virtual Trainer (Stage 3) - 18002VT3.....72-73

Network Solutions

Pg. 74- 78

- ATech Lab Integration.....74-78

Cutaways

Pg. 79- 85

- Locking Differential/Limited-Slip Rear Axle Cutaway - 126.....79
- Limited - Slip Rear Axle Cutaway - 127.....79
- Manual Transmission (RWD) Cutaway - 130.....80
- Manual Transaxle (FWD) Cutaway - 140.....80
- V5 Variable Displacement A/C Compressor Cutaway - 382.....80
- Power Steering Pump Cutaway - 506.....81
- Power Rack and Pinion Cutaway - 507.....81
- Cylinder Powertrain Cutaway Trainer - 680.....82
- Starter Cutaway - 813.....83
- Alternator Cutaway - 814.....83
- Transfer Case Cutaway Trainer - 1230.....84
- Planetary Gear - 1069.....85
- Common Rail Diesel Cutaway - 10300.....85
- Briggs & Stratton Small Engine Cutaway - XR950.....85

Accessories

Pg. 86- 87

- Optional Floor Model Legs.....86
- Optional Storage Case.....87

Models

Pg. 88- 89

- Maintenance and Light Repair (MLR) Plan.....88
- Automobile Service Technology (AST) / Master Automobile Service Technology (MAST) Plan.....89

ATech's Free Products and Services

To assist and inform all automotive and diesel educators, we offer the following:

E-NEWSLETTERS

Newsletters contain information about current technology and anticipated future technology, as well as other items of interest to technicians, instructors, students, and administrators. To view our most recent edition or to join the E-Newsletter visit: <https://www.atechtraining.com/educator-news2>

CONSULTING SERVICES

Due to our continual involvement with the automotive industry and educational associations, we offer informed, up-to-date assistance to help you develop or upgrade your automotive and diesel programs. For more information on lab design and consulting services visit: <https://www.atechtraining.com/lab-design>

WEB SITE

Contains newsletters, upcoming events, product information, employment opportunities, technical articles of interest, and new trainers. (www.atechtraining.com)

SOCIAL MEDIA

Showcases up-to-date events, new products, automotive technology news, and highlights events at schools and in the industry. Follow us on Instagram (atech_training), LinkedIn (ATech Training), Facebook (ATech Training), Twitter (@ATech_Training), YouTube (ATechTraining) and our LinkedIn (ATech Training) to stay connected. #ATechTraining

STAY SOCIAL

atech_training



/atechtraining



/company/atech-training-inc



@ATechTraining

/ATechTraining



ATech Training, Inc.

ATech's Free Products and Services

To assist and inform all automotive and diesel educators, we offer the following:

VIRTUAL TRAINING

In this Training, we will explore the key concepts and principles that will enhance your integration of ATech Trainers into your education program. This is a one on one training opportunity and will allow for flexibility with your schedule and training needs. For more Information on Virtual Training visit: <https://www.atechtraining.com/virtual-training-workshop>

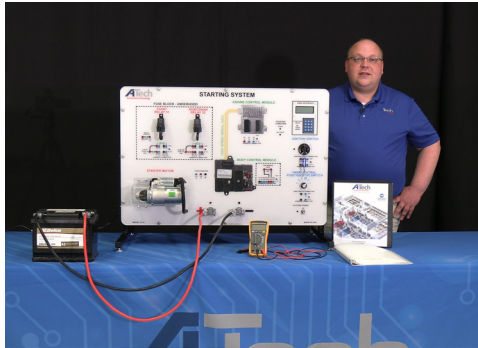

IN-HOUSE TRAINING

ATech offers training for our products to assist with knowledge and lab implementation. During Training, we will help train you on the equipment you already own so that you can be a more effective instructor in your classroom. There will also be an opportunity to try out many different trainers ATech has to offer. Training time will count towards ASE Education Foundation requirements. For more information on In-House training visit: <https://www.atechtraining.com/training>



AUTOMOTIVE CLASSROOM

Convenient to, but separate from, the lab / shop area
(Standard 9.6)

ATech Trainers

Automotive Electricity / Electronics
with Optional Computer Based Instruction

Multimedia and E-Learning Stations

(Standards 3.2 and 12)

Safety and First Aid

(Standards 9.2 and 9.10)

Cleanup Area with Student Lockers

(Standard 9.8)

Rest Rooms

For Male and Female Students
(Standard 9.8)

Secure Storage Area

For Tools, Parts and Supplies
(Standard 9.7)

Student Progress and Performance Standards

(Standards 7.6 and 7.7)

Automotive Shop

On-Vehicle Service and Repair Work
(Standard 7.15)



Proud Member of

Training Managers Council
ATMC

Atech Training, Inc

sales@atechtraining.com ♦ 1.888.738.9924

Page 8

Instructional Courseware

To advance quality and excellence in automotive service training, ATech provides trainer courseware. Each was developed to give instructors a detailed curriculum path to address all of a trainer's capabilities. Students benefit from this in-depth study and from a hands-on approach through on-trainer and on-vehicle activities. ASE Education Foundation Task and Record Keeping Sheets are included to ensure current automotive service standards are covered. The courseware consists of an Instructor Guide, Student Manual, and any applicable service information and/or reference material. A courseware site license permits copy and distribution to students.

ATech Instructional Courseware

Student-Oriented Learning Materials
(Standard 7)



Office Space

Separate and Convenient for Instructor's Use
(Standard 9.5)

Storage Space

For Instructional Supplies and Miscellaneous Items
(Standard 9.7)

Learning Resources

For Storage and Organization of Service Information, Professional Periodicals, and Student Resources
(Standards 3.1, 3.3, and 3.4)

ATech Instructional Courseware

Performance Standards
(Standard 7.7)

ATech Trainers

Automotive System Training Stations

ATech Trainers

Engine Performance Training Stations

ATech Trainers

Steering, Suspension, Brakes, Air Conditioning,
Transmission and Engine Training Stations

ATech Training, Inc

sales@atechtraining.com ♦ 1.888.738.9924

Page 9

Automotive Technology Lab

8400 Square Feet

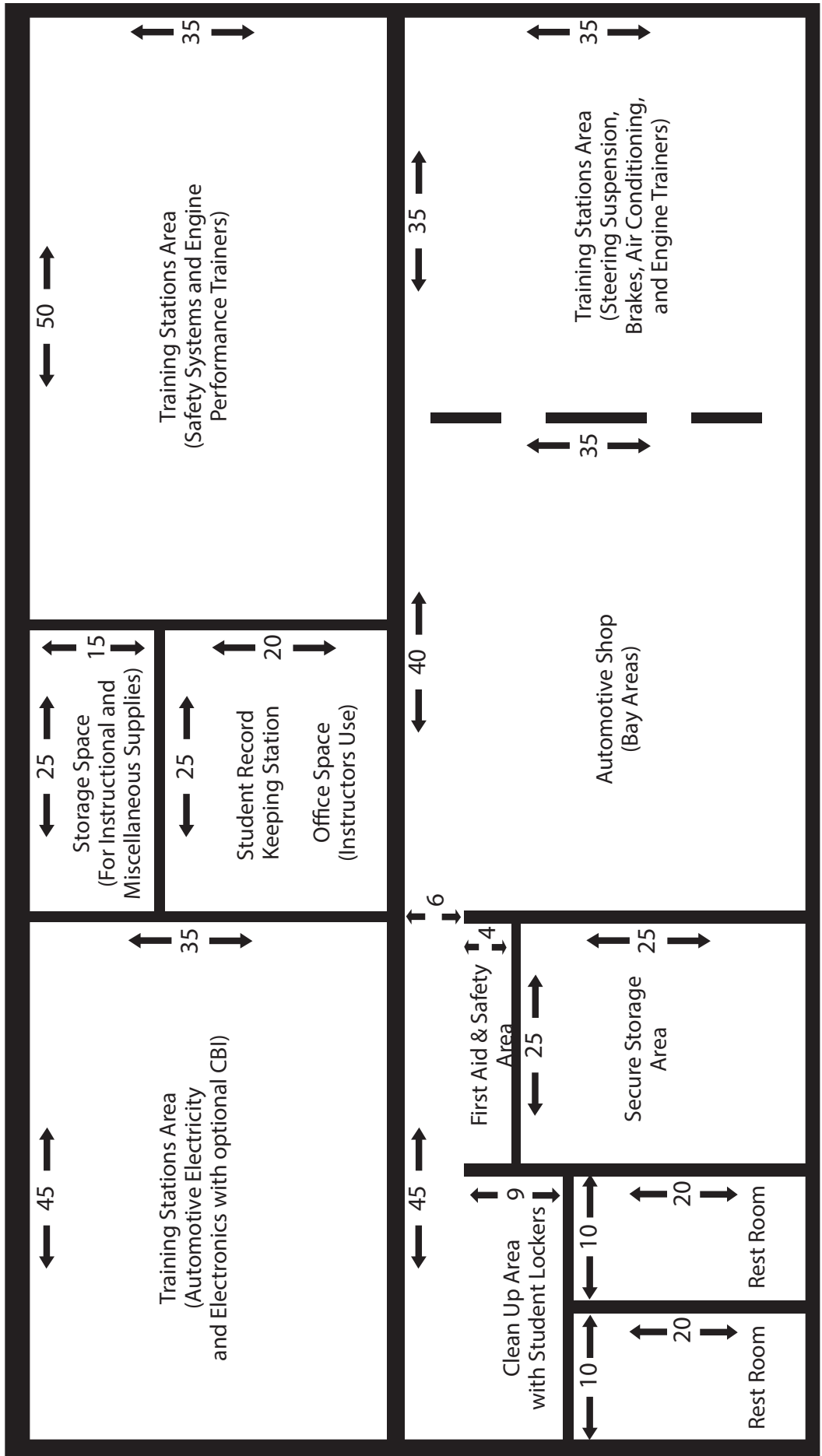

70

STEM Activity

Gears are one of the building blocks for many STEM paths.



Hands-On

Engaging students in the learning process creates a higher knowledge transfer.



What is included:

- 3 Cars
- Gears
- 3 Controllers
- 3 Stopwatches
- Batteries
- Activity Sheet
- Record Sheet
- Tape

Recruit Students

Market to potential students for your program through earlier contact opportunities.



STEM

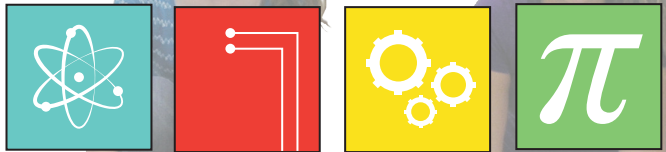

Science • Technology • Engineering • Math

Activity Recruitment

by

4Tech
Training.

Walton, KY

Automotive Systems

Air Bag System

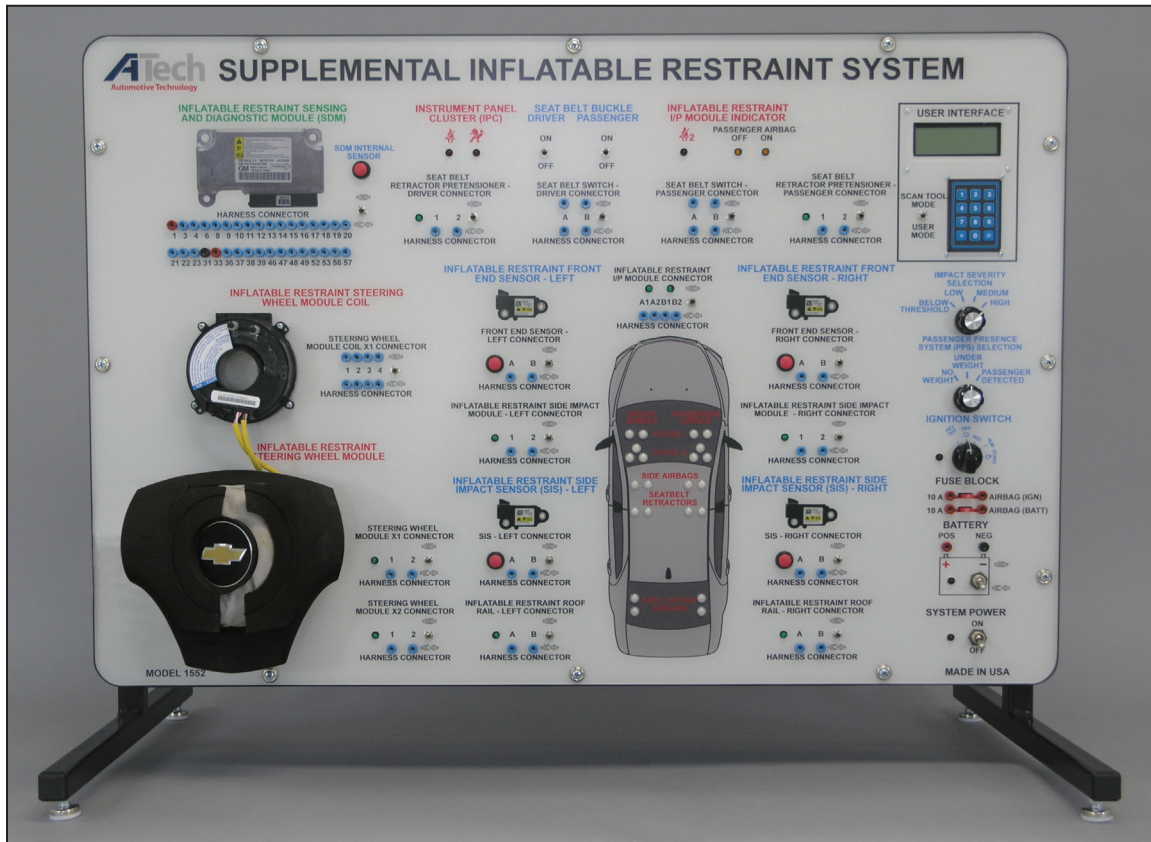

Supplemental Inflatable Restraint System Model 1552

The Supplemental Inflatable Restraint System (Model 1552) uses an actual SIR system that electrically responds and operates as in the automobile. The airbag portion of the trainer is a non-functional disarmed unit. The Supplemental Inflatable Restraint System is based on a CAN platform vehicle.

Features:

- Actual vehicle components, connectors, and factory wire colors
- Provides an advanced level of instruction by duplicating actual on-vehicle troubleshooting procedures
- Intermittent and hard faults can be inserted using the Classroom Management Program (CMP) via a computer connected to the trainer or over the ATech Lab System (ALS)
- Hard faults can be inserted by using the built-in keypad on the Supplemental Inflatable Restraint System
- Ability to perform actual service manual test procedures
- Compatible with Classroom Management Program (CMP)
- Courseware includes Instructor Guide, Student Manual, and Service Manual Information
- Crash simulation using sensor impact push switches and bag deployment strobe
- Study of removal and installation of system components
- Performing airbag disposal procedures
- Includes external power supply for uninterrupted fault operation
- User interface displays built-in scan tool data

Automotive Systems

Brakes

Trainer Features:

- New drum / disc brakes
- Operating hydraulic system
- Includes: power assist, parking brake, electrical circuits and wheel bearings
- Real world system skills and knowledge
- Powder-coated frame
- Courseware included

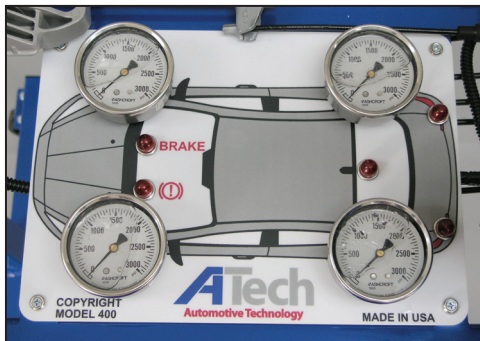

Drum / Disc Brake (4-Wheel) Model 400

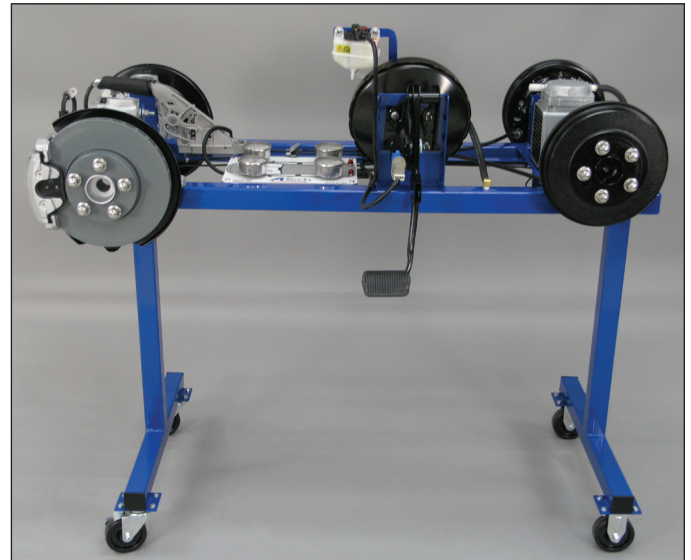

DELCO DBC7 ABS/TCS System Model 1432

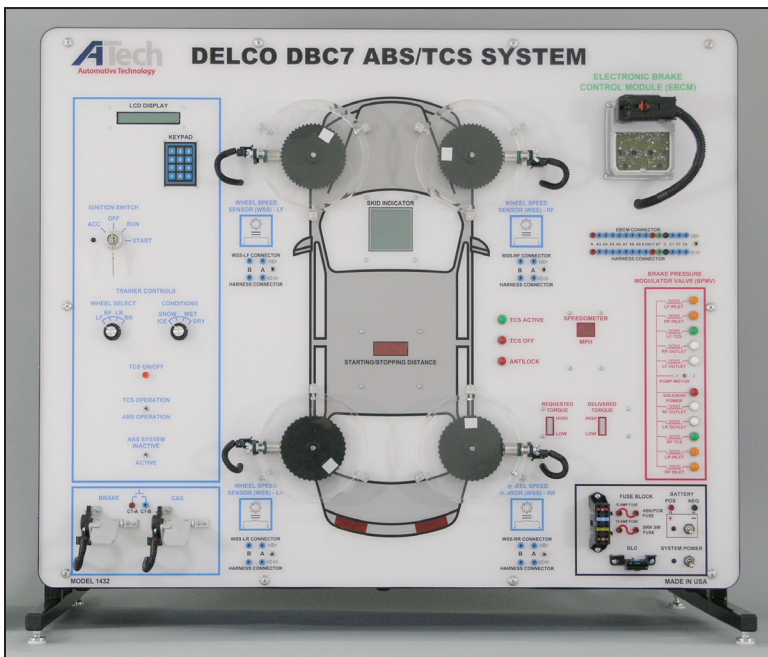

Trainer Features:

- Realistic accelerator and brake pedal operation
- Selection of "controlled wheel" (LF, RF, LR, RR)
- Road condition selections: dry, wet, snow or ice
- Torque request/torque delivered indicators
- BPMV Solenoid operation indicators
- Courseware included

- Anti-lock mode or traction control mode operation
- Class 2 "bus" for communications with Tech 2™ scan tool recommended (Tech 2™ not included)
- Fault insertion locally with keypad or remotely via CMP

Automotive Systems

Heating Ventilation and Air Conditioning (HVAC)

Engine Cooling Fan System Model 310FJ

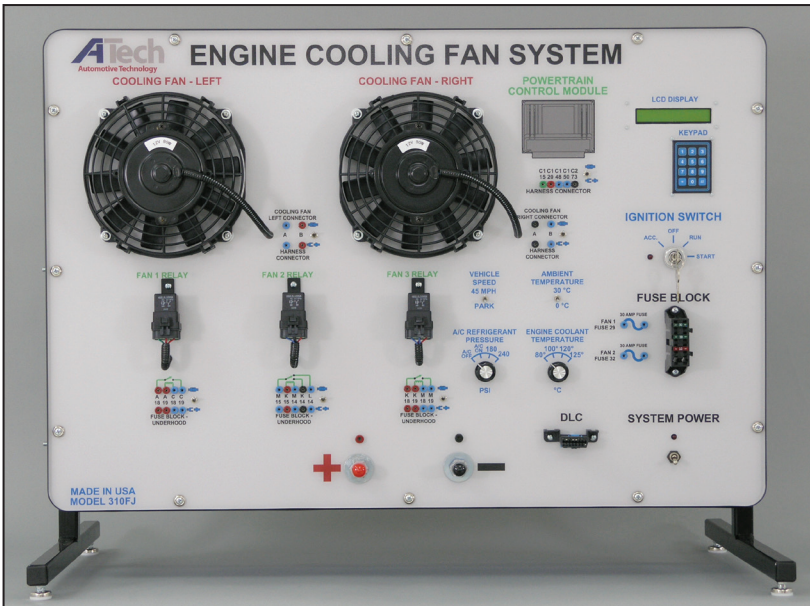

- Presents the live operation and study of a late-model system
- New-model vehicle components and connectors
- Capable of actual service manual test procedures
- Connects to Tech 2™ scan tool from DLC connector (Tech 2™ not included)
- Courseware included

Fan Speed Control Model 311

The Fan Speed Control (Model 311) presents the hands-on construction, study and live operation of a Fan Speed Control System as found on late-model General Motors vehicles. Students follow printed schematics to wire up either a single speed single fan system or a two-speed two fan system. The trainer circuits use the same wire colors as the manufacturer's wiring diagram. Incandescent bulbs are substituted for actual cooling fan motors for safety purposes.

Activities Include:

- Cooling Fan Speed Control Operation
- Electrical Troubleshooting
- Reading, Analyzing and Interpreting a Wiring Diagram
- Relay and Series-Parallel Circuit Operation

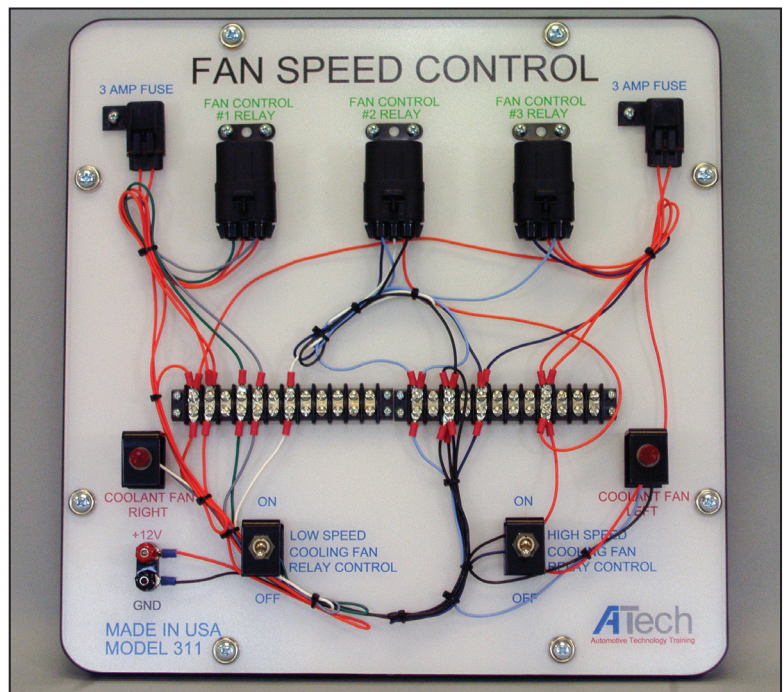

* Requires 12VDC Power Supply

Automotive Systems

Heating Ventilation and Air Conditioning (HVAC)

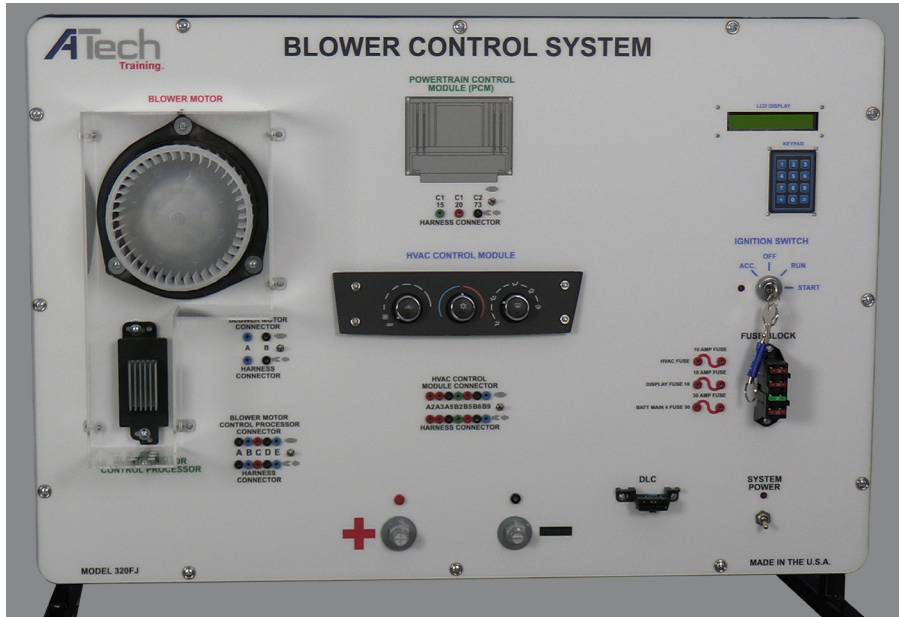

**Blower Control System
Model 320FJ**

- Faults can be inserted via keypad, local computer, or ATech Lab System (ALS)
- Includes internal power supply for fault activation
- Power provided by 12 VDC battery or external power supply (option available)
- Courseware included



**Air Conditioning R1234yf
Model 1352**

- 110V 2HP Motor
- Variable Displacement Compressor
- Thermostatic Expansion Valve (TXV)
- Refrigerant High and Low Side Pressure Faulting
- Frame Designed to Fit a Standard Classroom Door Width
- Classroom Management Program (CMP)
- Compatible Courseware Included: Student Manual and Instructor Guide

Atech Training, Inc
sales@atechtraining.com ♦ 1.888.738.9924

Automotive Systems

Heating Ventilation and Air Conditioning (HVAC)

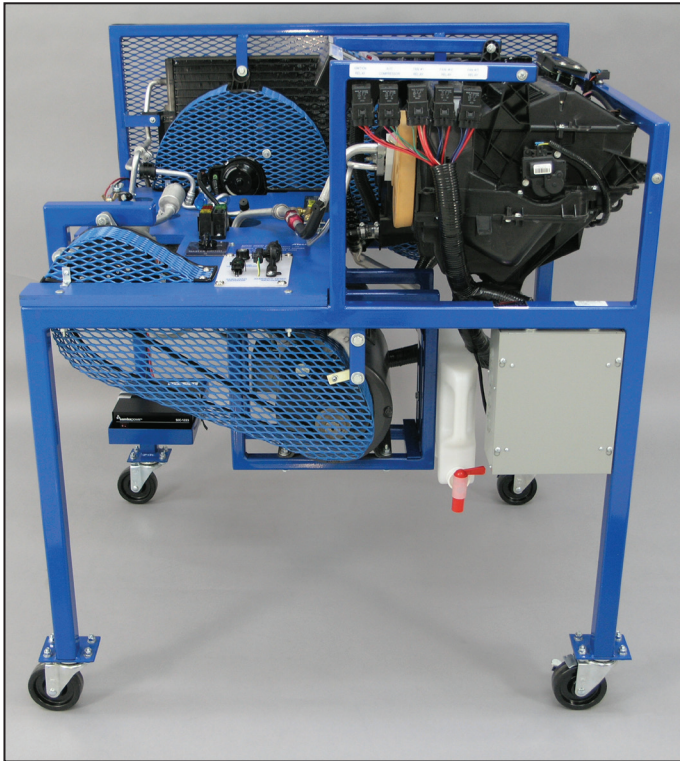

Side View

Air Conditioning with Automatic Climate Control Model 1351

- Functional R134A A/C system
- Automatic / manual dual zone climate control
- Compact variable compressor (CVC6)
- Thermostatic expansion valve (TXV)
- Includes refrigerant 'liquid line' control valve for "pressure faulting"
- Electrical faulting either locally via keypad or remotely via CMP
- Selectable interior temperature settings
- Tip jacks for DVOM measurements
- 220V 5HP motor
- Powder-coated frame
- Courseware included

Activities Include:

- Principles of refrigeration
- Basic refrigerant cycle
- Compressors & control components
- Condenser and evaporator
- Receiver-dryer / accumulator
- Metering components
- Safety precautions & environmental concerns
- Refrigerant system tests
- Leak detection
- Refrigerant system recovery, recycling & recharging
- Cooling fan operation
- Cooling fan diagnosis
- Air distribution overview and controls
- Blower controls and diagnosis
- Automatic climate control operation
- Automatic climate control diagnostics
- Strategy-based diagnosis



Front View

Automotive Systems

Smarter Car

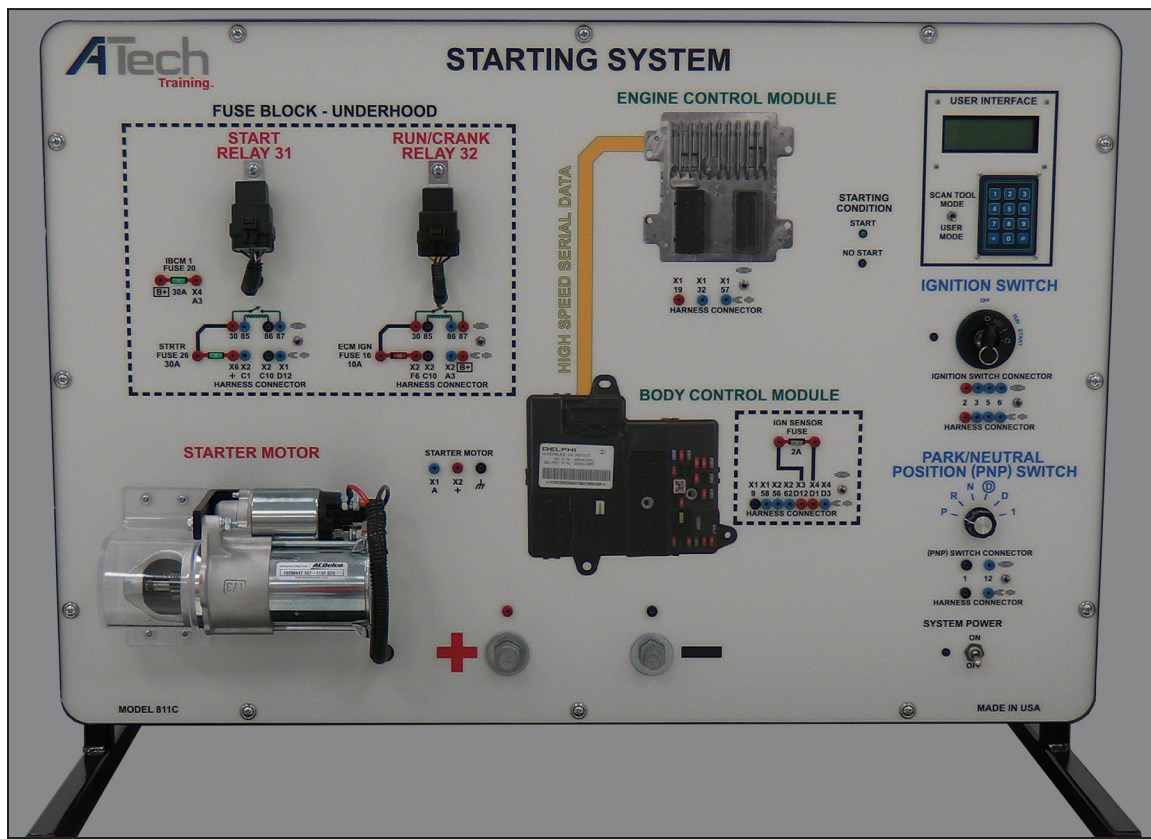

Starting System Model 811C

The Starting System (Model 811C) is part of an electrical system program which presents the live operation and study of starter motor systems. This trainer allows for instructor demonstration, student hands-on reinforcement, and troubleshooting practice. Powered by a 12VDC automotive battery (not included). The Starting System is based on a CAN platform vehicle.

Features:

- New vehicle components, connectors, and factory wire colors
- Provides an advanced level of instruction by duplicating actual on-vehicle troubleshooting procedures
- Intermittent and hard faults can be inserted using the Classroom Management Program (CMP) via a computer connected to the trainer or over the ATECH Lab System (ALS)
- Hard faults can be inserted by using the built-in keypad on the Starting System Trainer.
- Ability to perform actual service manual test procedures
- Compatible with Classroom Management Program (CMP)
- Courseware includes Instructor Guide, Student Manual, and Service Manual Information
- Battery posts are protected against polarity reversal
- Includes external power supply for uninterrupted fault operation
- User interface displays built-in scan tool data

Automotive Systems Smarter Car

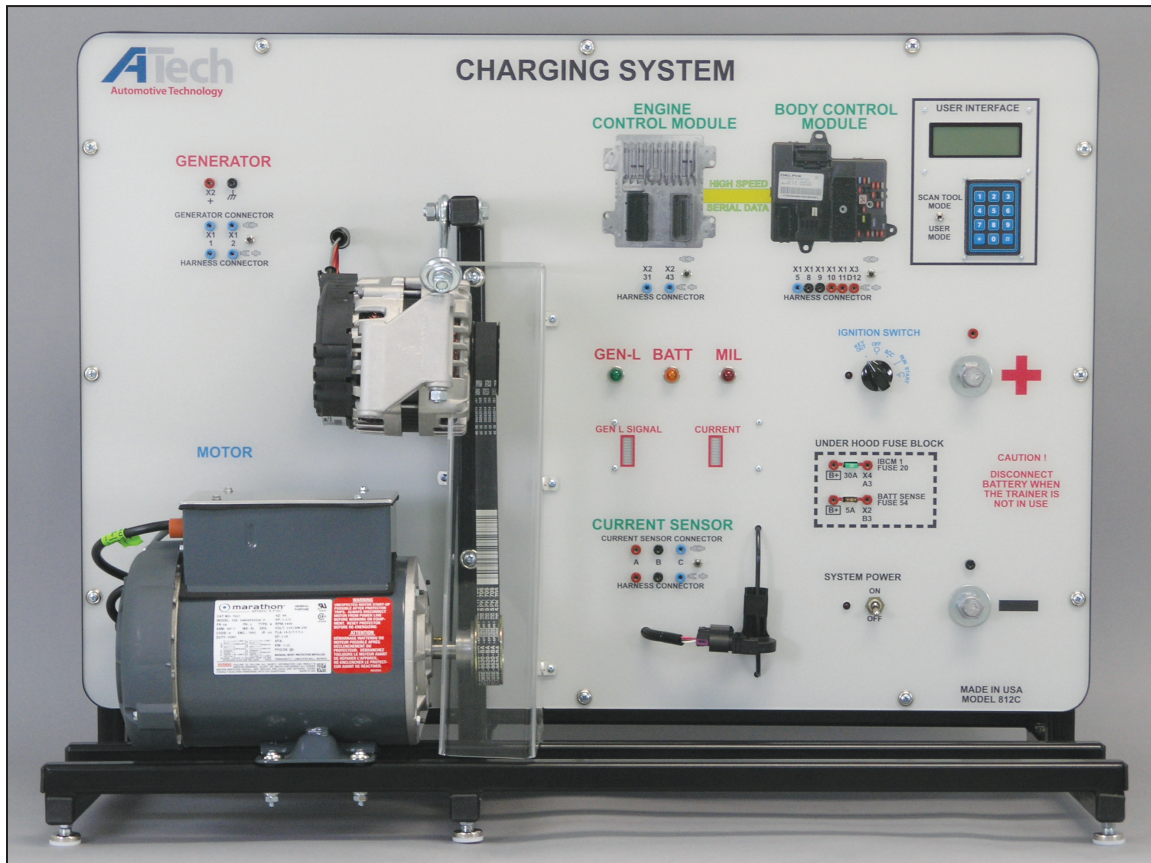

Charging System Model 812C

The Charging System (Model 812C) is part of an electrical system program which presents the live operation and study of charging systems. This trainer allows for instructor demonstration, student hands-on reinforcement, and troubleshooting practice. Powered by a 12VDC automotive battery (not included). The Charging System is based on a CAN platform vehicle.

Features:

- New vehicle components, connectors, and factory wire colors
- Provides an advanced level of instruction by duplicating actual on-vehicle troubleshooting procedures
- Intermittent and hard faults can be inserted using the Classroom Management Program (CMP) via a computer connected to the trainer or over the ATECH Lab System (ALS)
- Hard faults can be inserted by using the built-in keypad on the Charging System Trainer
- Ability to perform service manual test procedures
- Compatible with Classroom Management Program (CMP)
- Courseware includes Instructor Guide, Student Manual, and Service Manual Information
- Battery posts are protected against polarity reversal
- Includes external power supply for uninterrupted fault operation
- User interface displays built-in scan tool data

Automotive Systems Smarter Car

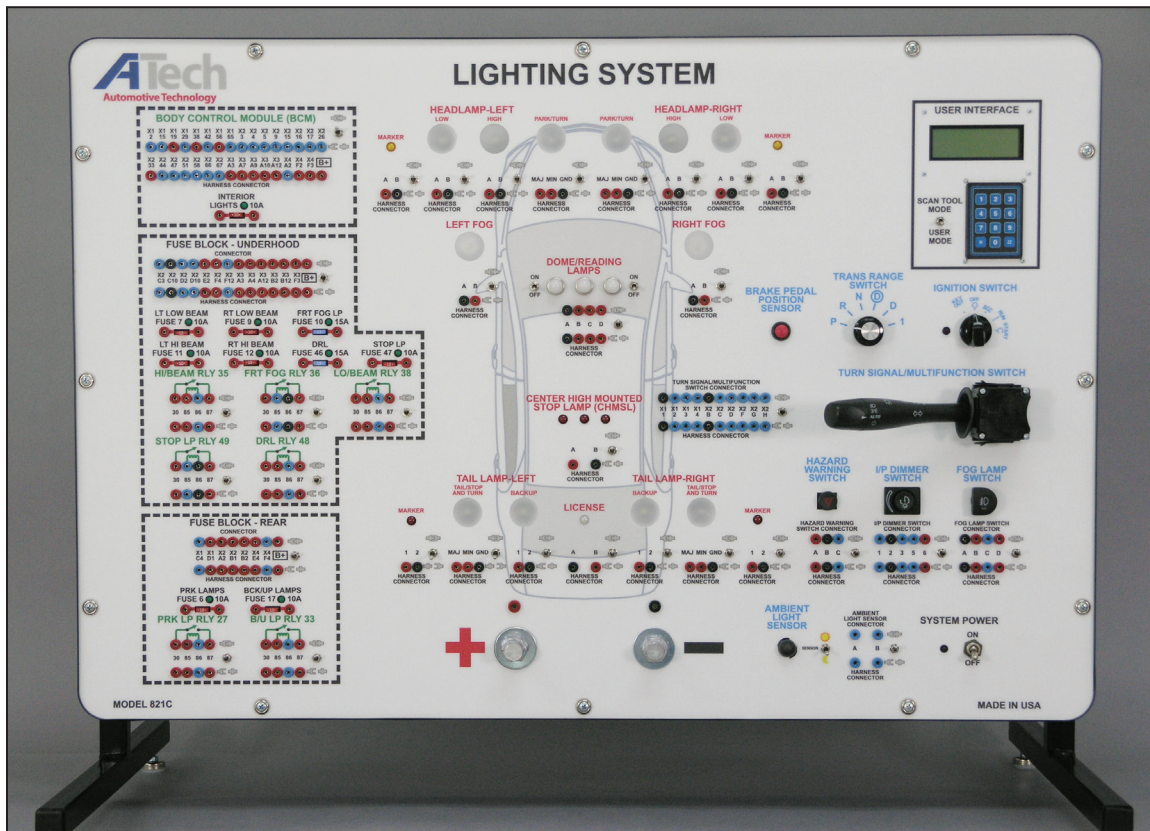

Lighting System Model 821C

The Lighting System (Model 821C) is designed to teach computer and network-controlled automotive lighting system operation. This trainer allows for instructor demonstration, student hands-on reinforcement, and troubleshooting practice. Powered by a 12VDC automotive battery or a 12VDC/23AMP (minimum) power supply (not included). The Lighting System is based on a CAN platform vehicle.

Features:

- New vehicle components, connectors, and factory wire colors
- Provides an advanced level of instruction by duplicating actual on-vehicle troubleshooting procedures
- Intermittent and hard faults can be inserted using the Classroom Management Program (CMP) via a computer connected to the trainer or over the ATech Lab System (ALS)
- Hard faults can be inserted by using the built-in keypad on the Lighting System Trainer
- Ability to perform actual service manual test procedures
- Compatible with Classroom Management Program (CMP)
- Courseware includes Instructor Guide, Student Manual, and Service Manual Information
- Battery posts are protected against polarity reversal
- Includes external power supply for uninterrupted fault operation
- User interface displays built-in scan tool data

Automotive Systems Smarter Car

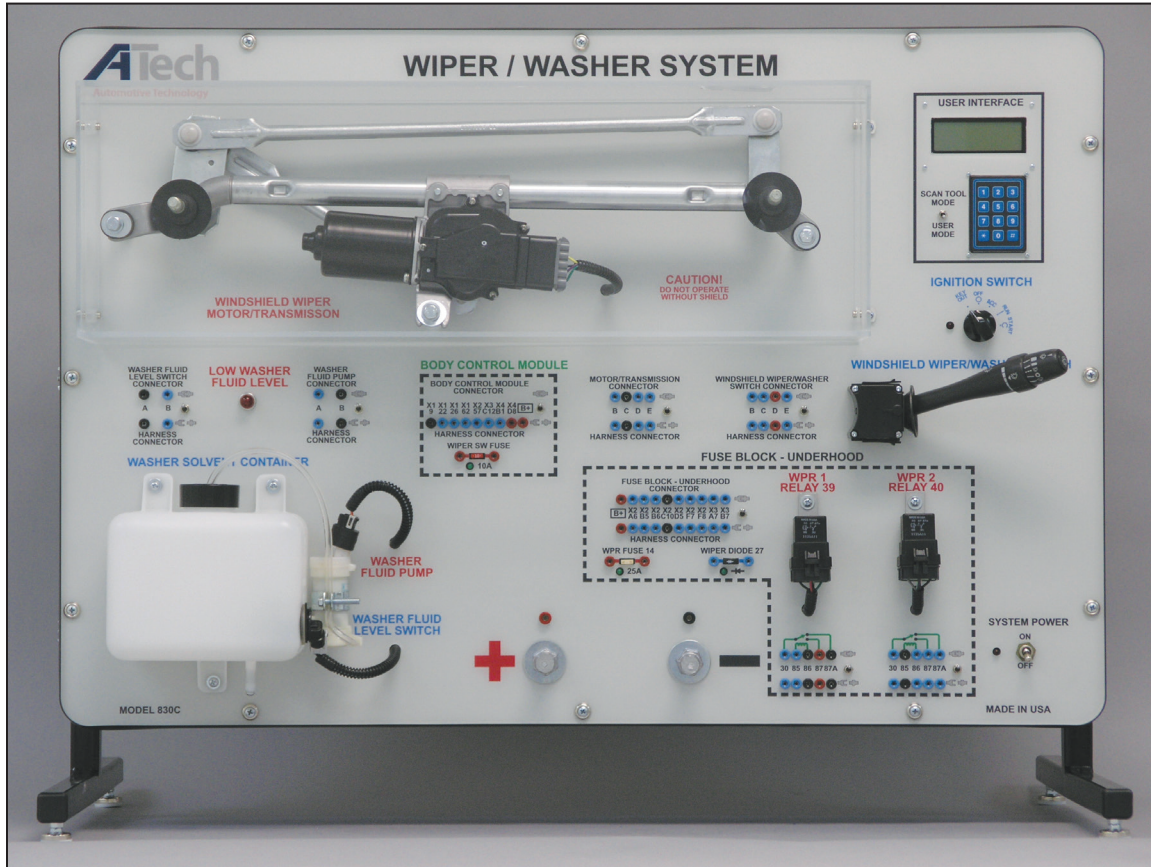

Wiper / Washer System Model 830C

The Wiper / Washer System (Model 830C) is part of an electrical system program which presents the live operation and study of wiper / washer systems. This trainer allows for instructor demonstration, student hands-on reinforcement, and troubleshooting practice. Powered by a 12VDC automotive battery or a 12VDC/23A power supply (not included). The Wiper / Washer System is based on a CAN platform vehicle.

Features:

- New vehicle components, connectors, and factory wire colors
- Provides an advanced level of instruction by duplicating actual on-vehicle troubleshooting procedures
- Intermittent and hard faults can be inserted using the Classroom Management Program (CMP) via a computer connected to the trainer or over the ATech Lab System (ALS)
- Hard faults can be inserted by using the built-in keypad on the Wiper / Washer System Trainer
- Ability to perform actual service manual test procedures
- Compatible with Classroom Management Program (CMP)
- Courseware includes Instructor Guide, Student Manual, and Service Manual Information
- Battery posts are protected against polarity reversal
- Includes external power supply for uninterrupted fault operation
- User interface displays built-in scan tool data

Automotive Systems

Smarter Car

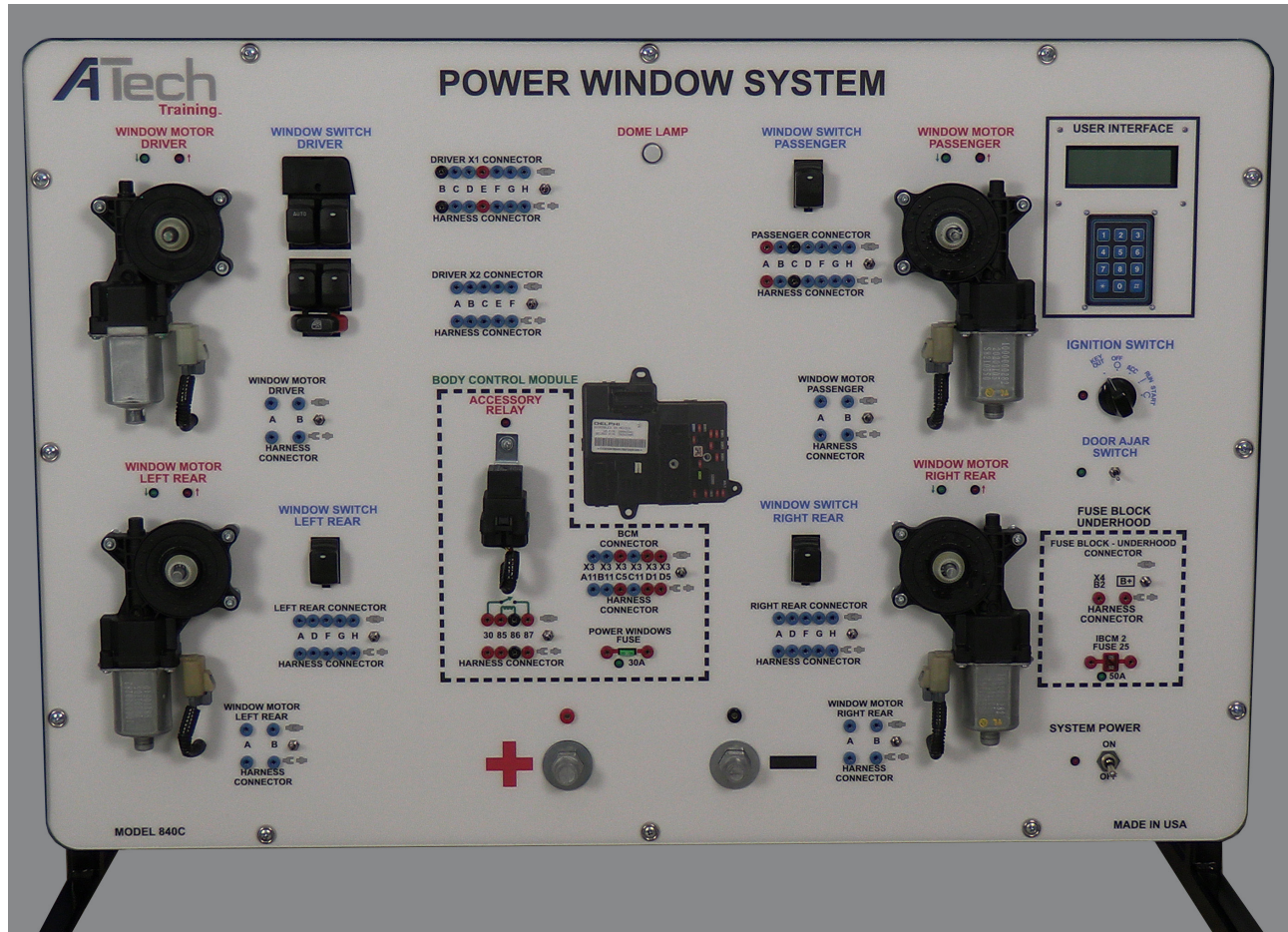

Power Window System Model 840C

The Power Window System (Model 840C) is designed to teach computer and network-controlled automotive power window operation. This trainer allows for instructor demonstration, student hands-on reinforcement, and troubleshooting practice. Powered by a 12VDC automotive battery or a 12VDC/23A power supply (not included). The Power Window System is based on a CAN platform vehicle.

Features:

- New vehicle components, connectors, and factory wire colors
- Provides an advanced level of instruction by duplicating actual on-vehicle troubleshooting procedures
- Intermittent and hard faults can be inserted using the Classroom Management Program (CMP) via a computer connected to the trainer or over the ATech Lab System (ALS)
- Hard faults can be inserted by using the built-in keypad on the Power Window System Trainer
- Ability to perform actual service manual test procedures
- Compatible with Classroom Management Program (CMP)
- Courseware includes Instructor Guide, Student Manual, and Service Manual Information
- Battery posts are protected against polarity reversal
- Includes external power supply for uninterrupted fault operation

Automotive Systems

Smarter Car

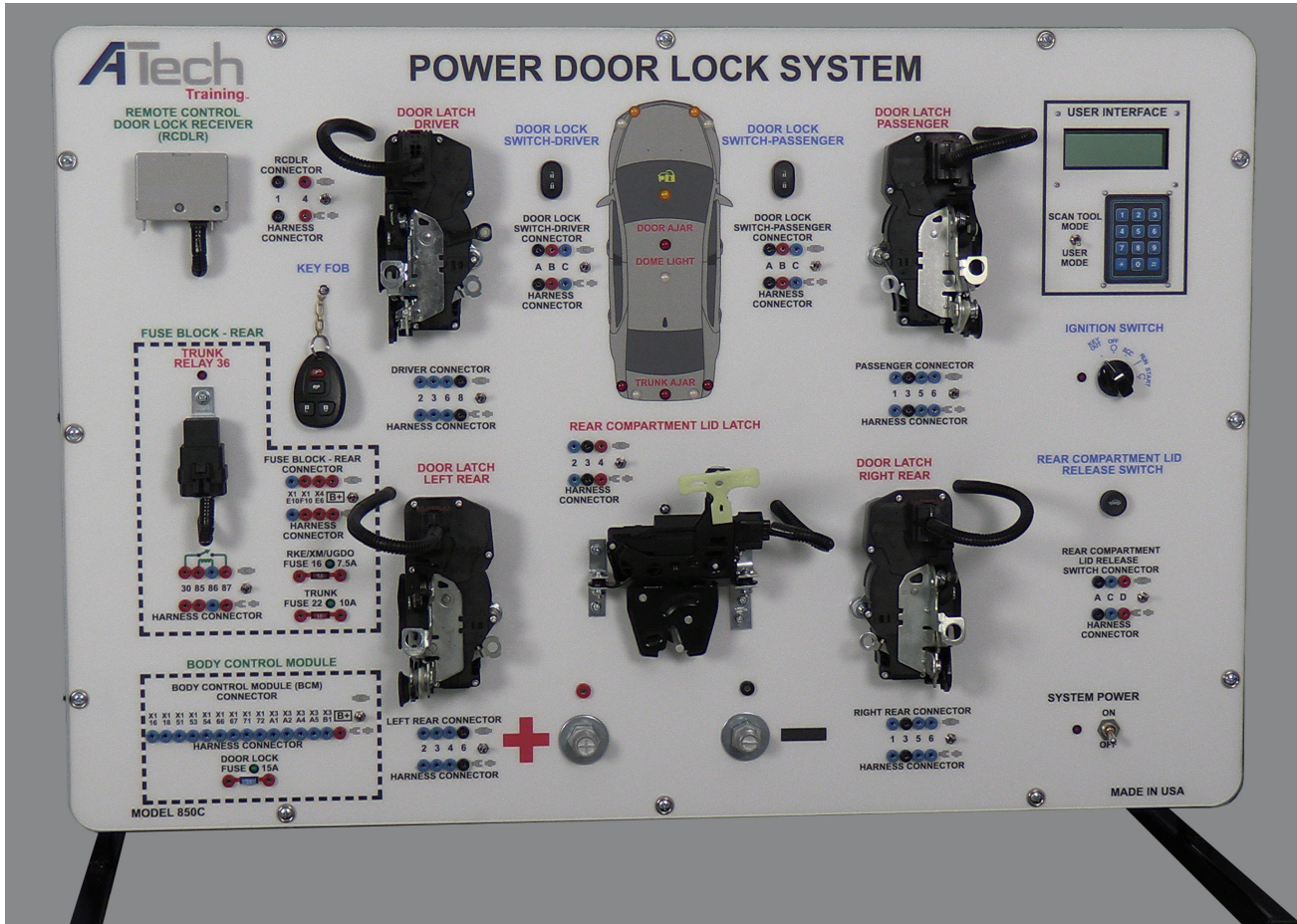

Power Door Lock System Model 850C

The Power Door Lock System (Model 850C) is designed to teach computer and network-controlled automotive door lock and theft deterrent system operation. This trainer allows for instructor demonstration, student hands-on reinforcement, and troubleshooting practice. Powered by a 12VDC automotive battery or a 12VDC/23A power supply (not included). The Power Door Lock System is based on a CAN platform vehicle.

Features:

- New vehicle components, connectors, and factory wire colors
- The key fob can be used to lock and unlock the doors
- Built-in horn (buzzer)
- Provides an advanced level of instruction by duplicating actual on-vehicle troubleshooting procedures
- Intermittent and hard faults can be inserted using the Classroom Management Program (CMP) via a computer connected to the trainer or over the ATech Lab System (ALS)
- Hard faults can be inserted by using the built-in keypad on the Power Door Lock System Trainer
- Ability to perform actual service manual test procedures
- Compatible with Classroom Management Program (CMP)
- Courseware includes Instructor Guide, Student Manual, and Service Manual Information
- Battery posts are protected against polarity reversal
- Includes external power supply for uninterrupted fault operation
- User interface displays built-in scan tool data

Automotive Systems Smarter Car

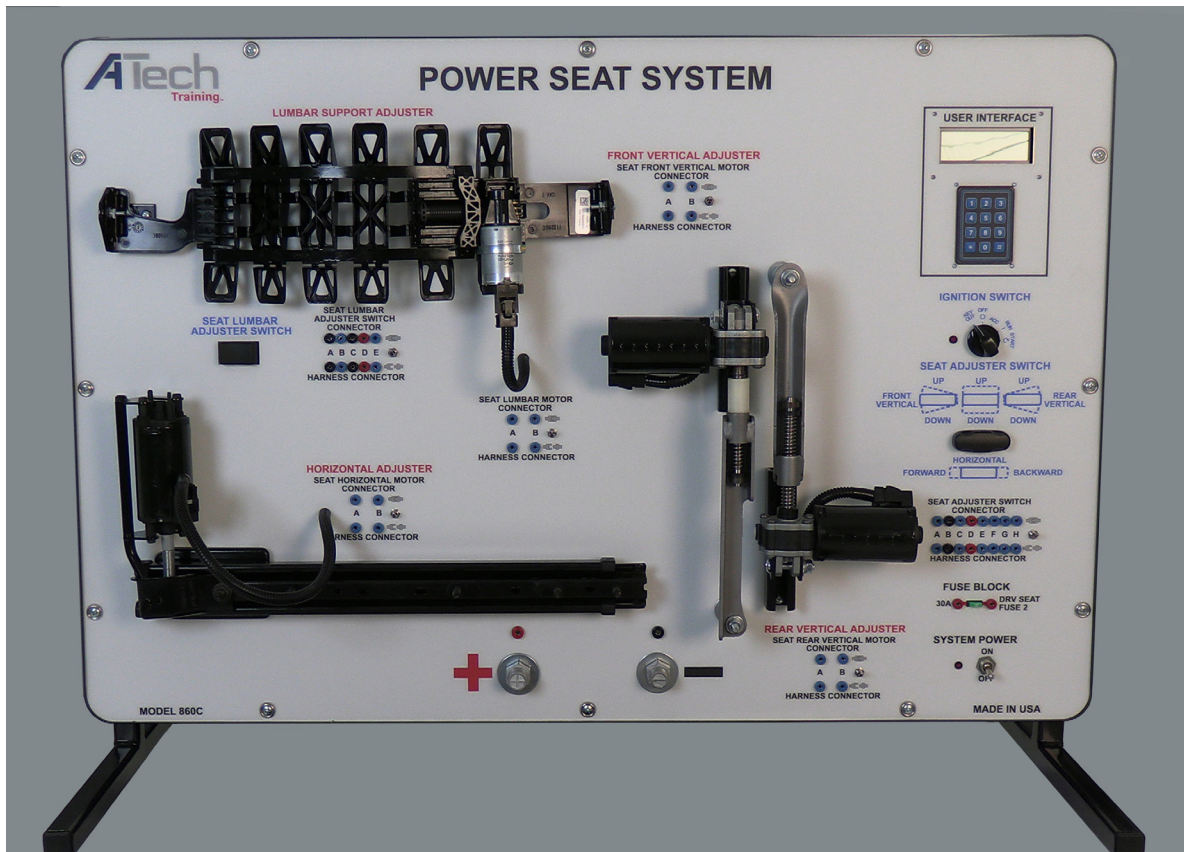

Power Seat System Model 860C

The Power Seat System (Model 860C) is part of an electrical system program which presents the live operation and study of power seat systems. This trainer allows for instructor demonstration, student hands-on reinforcement, and troubleshooting practice. Powered by a 12VDC automotive battery or 12VDC/23A power supply (not included). The Power Seat System is based on a CAN platform vehicle.

Features:

- Actual vehicle components, connectors, and factory wire colors
- Provides an advanced level of instruction by duplicating actual on-vehicle troubleshooting procedures
- Intermittent and hard fault codes can be inserted using the Classroom Management Program (CMP) via a computer connected to the trainer or over the A-Tech Lab System (ALS)
- Hard faults can be inserted by using the built-in keypad on the Power Seat System Trainer
- Ability to perform actual service manual test procedures
- Compatible with Classroom Management Program (CMP)
- Courseware includes Instructor Guide, Student Manual, and Service Manual Information
- Battery posts are protected against polarity reversal
- Includes external power supply for uninterrupted fault operation

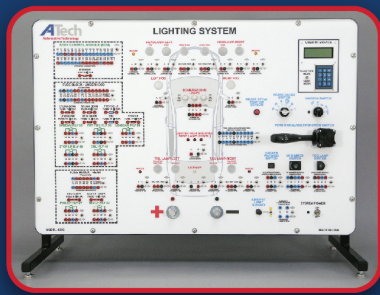

**Lighting System
(821C)**



**Wiper/Washer System
(830C)**

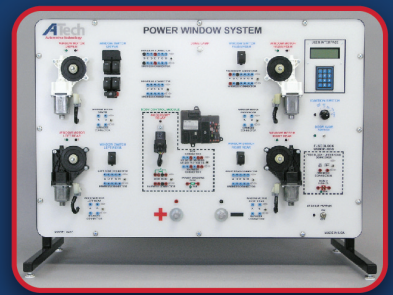

**Power Window System
(840C)**

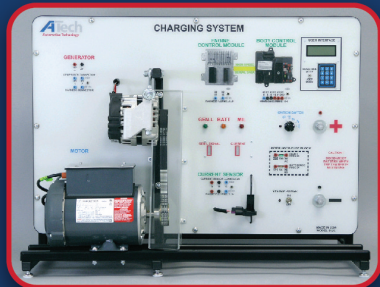

**Charging System
(812C)**



**Atech Lab System
(ALS)**

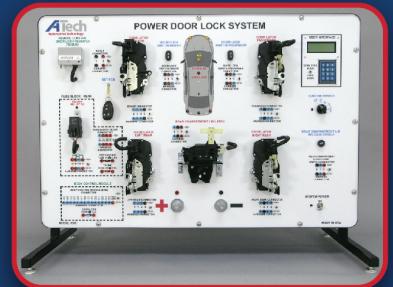

**Power Door Lock System
(850C)**

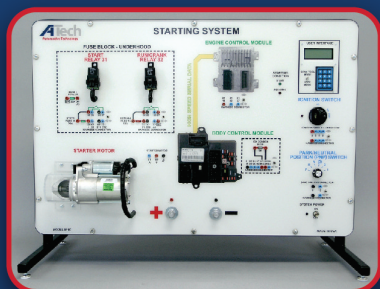

**Starting System
(811C)**



Instructor's Computer

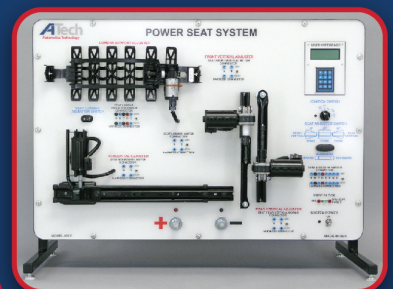

**Power Seat System
(860C)**



"Smarter Car"



Accredited Training Provider

Enhance student learning by using the entire vehicle with a "Class Under The Hood"

Features:

- Configuration simultaneously allows a class to study and troubleshoot vehicle systems
- Insert intermittent and hard faults with the Classroom Management Program (CMP)
- Includes Courseware: Instructor Guide, Student Manual, Service Information
- Create your "Smarter Car" lab with trainers from several ASE® areas
- CMP records student answers

 12290 Chandler Drive
Walton, Ky 41094



AtechTraining.com
sales@atechtraining.com



1.888.738.9924

Atech Training, Inc
sales@atechtraining.com ♦ 1.888.738.9924

Automotive Systems

Steering and Suspension



Driveline Simulator Model 250

The Driveline Trainer demonstrates the various setups of a driveline. Operate the driveline in-phase or out-of-phase. Setup with variable and extreme angles. Take measurements and use the level gauges to observe angles. See or hear the sprocket speed differences as you make changes.

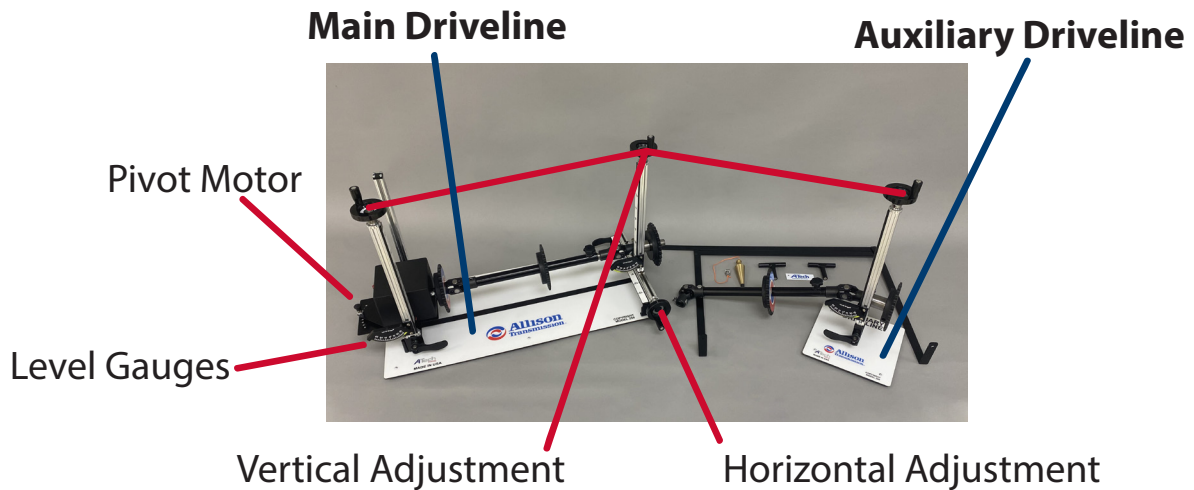

Variable Angles

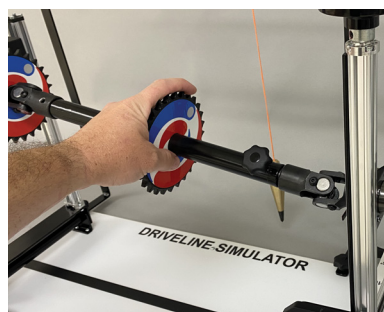

Safe Operation



Extreme Angles

Automotive Systems

Steering and Suspension



Suspension and Steering System Model 500

- New vehicle components
- Includes operating McPherson struts, rack and pinion, and power steering
- On-board hydraulics operate suspension without impairing wheels
- Folding steering wheel and casters for easy storage
- Powder-coated frame
- Courseware included



"My new A-Tech Trainers are excellent teaching tools for student technicians...the units are user-friendly...the course materials and trainers have been designed so each person using this system can learn by doing. These trainers are a great help to me as a teacher to better manage student time. It works!"

Gulf Coast Community College
Gautier, MS

Automotive Systems

Steering and Suspension

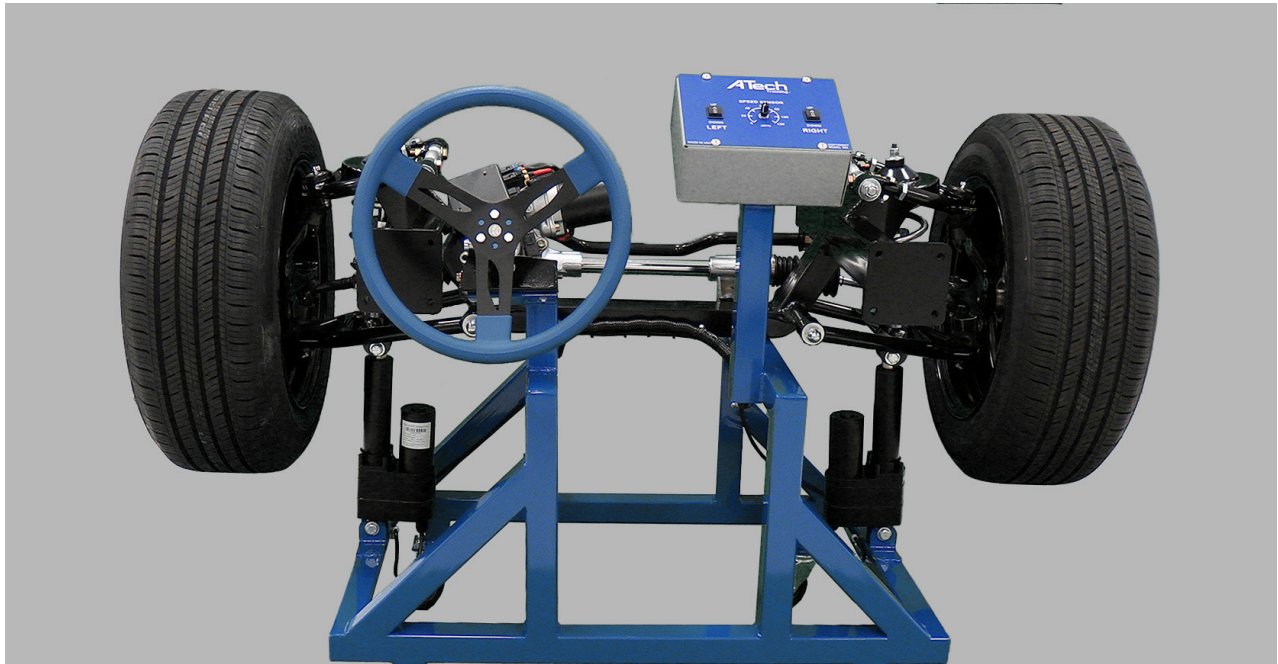

Suspension and Steering System Model 500E

ATech designed the Electronic Power Steering and Suspension System (Model 500E) trainer to teach the basic principles of the suspension and steering system. This trainer allows for instructor demonstration/presentation as well as hands-on reinforcement and troubleshooting experience.

- Lower Control Arms
- Steering Spindles
- Cross Member
- Tie Rod Ends
- Sway Bar
- Serviceable Ball Joints
- Wheel and Tire Assemblies
- Adjustable Coil Over Springs
- Quick Disconnect Steering Wheel
- Electronic Power Steering Motor and ECU
- Dual Adjustable Coil Over Shocks
- Adjustable Upper Control Arm Assemblies
- Manual Rack and Pinion Steering Gear Assembly
- Aluminum Hubs with Serviceable Tapered Roller Bearings

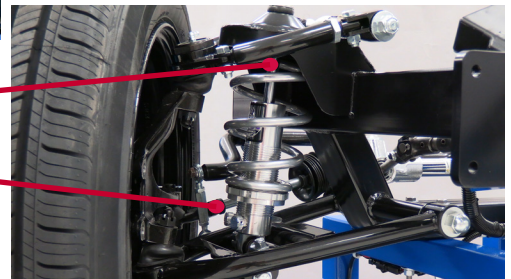
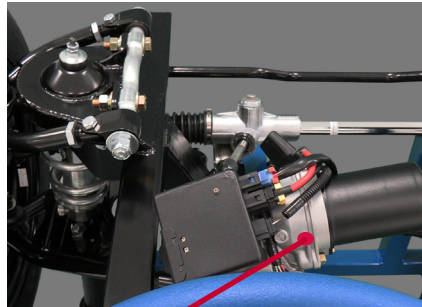

Features:

- Demonstrates front tire alignment angles
- Duplicates on-vehicle troubleshooting
- Courseware included: Student Manual, Instructor
- Trainer is 32" X 66" X 44" allowing it to fit through a standard door frame
- On-board electronic actuators simulating steering angles under different driving conditions

Automotive Systems

Transmissions and Transaxles



Manual Transaxle Rebuild Model 110

- Recycled transmission or transaxle with clutch
- Rotating rebuild stand with component storage and drain pan
- Powder-coated frame
- ASE task list and record keeping sheets

Electronic Automatic Transaxle Rebuild Model 1210

GM • FORD

- Recycled transaxle
- Rotating rebuild stand with component storage and drain pan
- Powder-coated frame
- ASE task list and record keeping sheets



Automotive Systems

Transmissions and Transaxles

Electronic Automatic Transmission Rebuild Model 1220

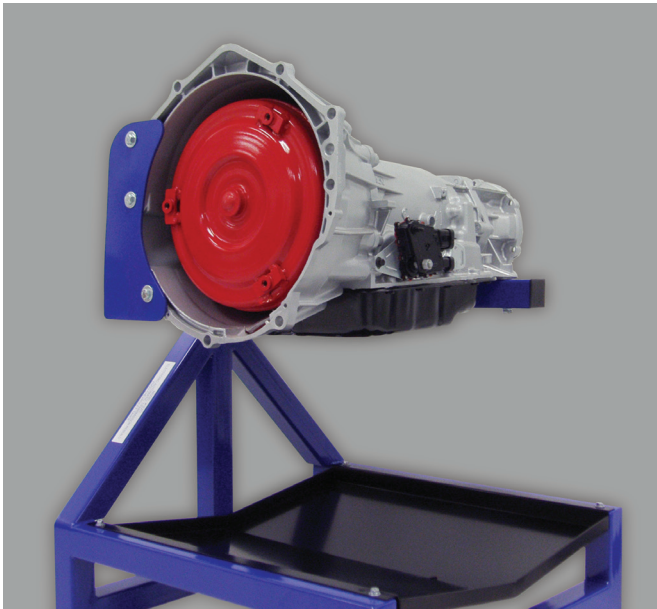

GM • FORD

- Recycled transmission
- Rotating rebuild stand with component storage and drain pan
- Powder-coated frame
- ASE task list and record keeping sheets

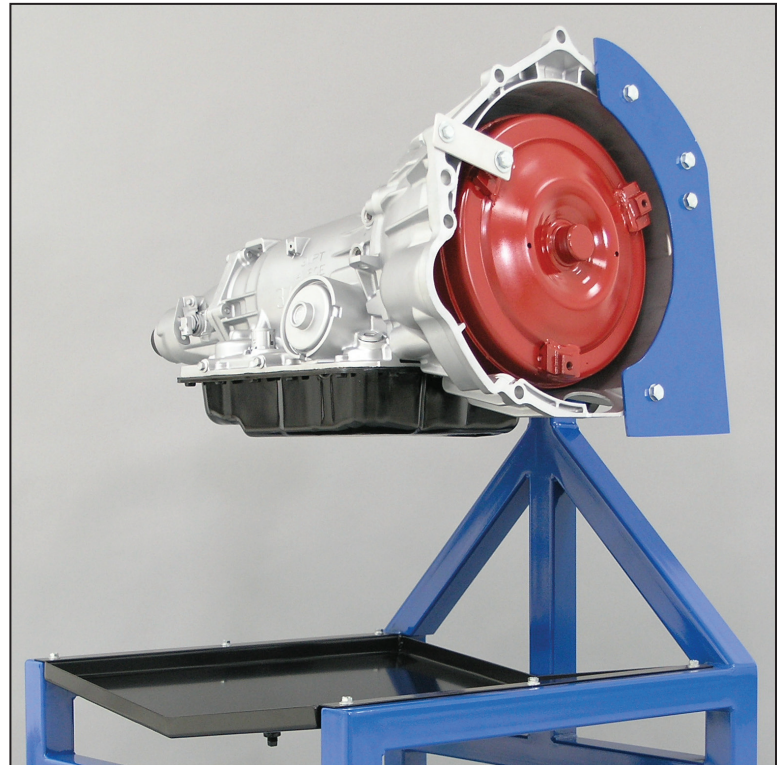

"During the 'Train the Trainer' program for the LX5, many of the instructors were curious as to how ATech could make the trainer operate so realistically. Subsequently, the back was removed to view the internal components. The group was amazed. This trainer is, without a doubt, the most professionally designed and constructed trainer GM has ever had built." GM 3.5 Liter - LX5 Ignition

General Motors
Training Center Director

"WOW? I am shocked, and pleased all at the same time! I would love to send you a picture of our lab when we get the new board. We are very proud of our set up and I am always looking for new things to add to it (we are almost out of room). I appreciate your help and you guys have always been very kind and helpful over the phone."

Automotive Electrical / Electronics Instructor

Electrical & Electronic Systems

Electrical/Electronic

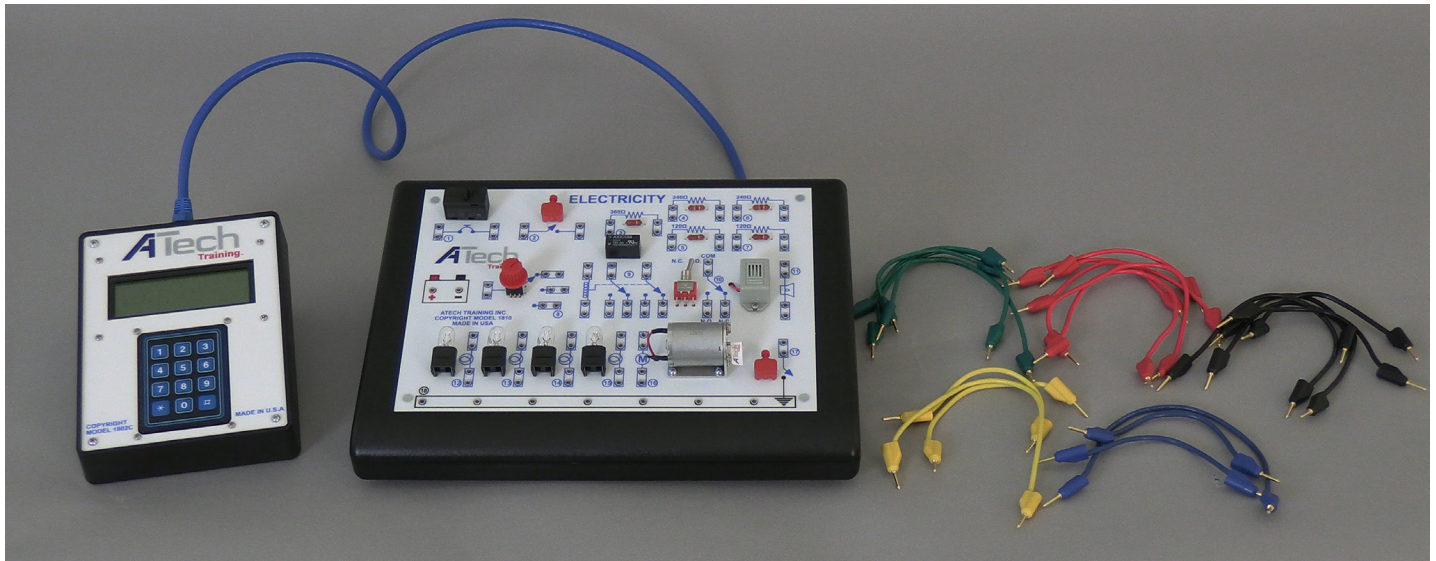

Electricity Model 1810

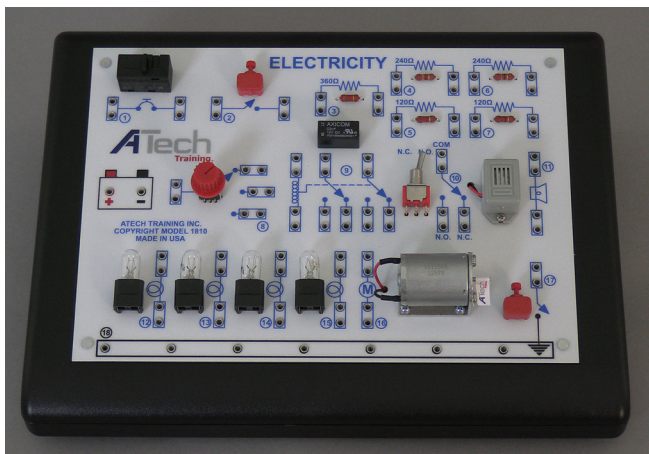

The Electricity (Model 1810) trainer is a hands-on study of basic automotive electricity. The trainer features real fixed components, wire terminals, 15-Volt power supply. Fault insertion capability with optional Keypad (Model 1802C) or with Class Management Program (CMP) and CBI. Included is a USB drive containing the Student Manual, Instructor Guide and an on-site copy license to allow for the reproduction of instructional materials for use in the classroom.

- Meter Usage (Volts, Ohms, Amps)
- Series, Parallel, and Series-Parallel Circuits
- Vehicle Automotive Circuits
- Service Information Schematics
- Troubleshooting Practice
- Competency Testing



Optional Storage Case available.

Electrical & Electronic Systems

Electrical/Electronic

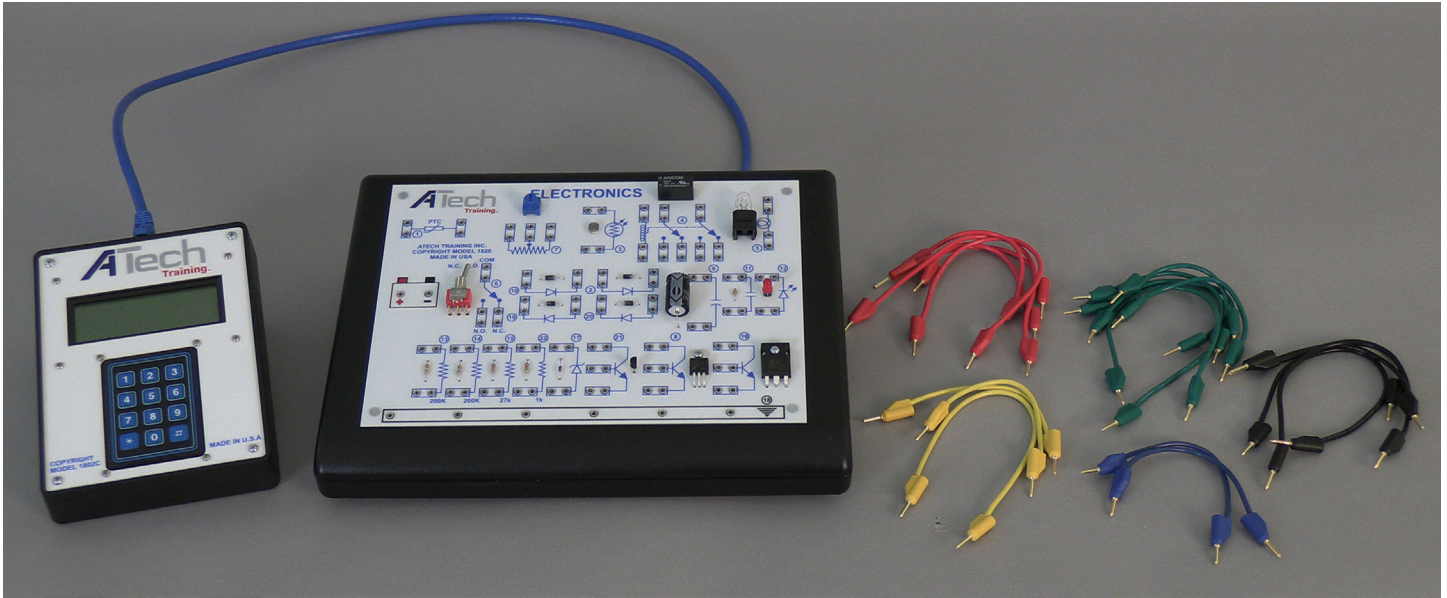

Electronics Model 1820

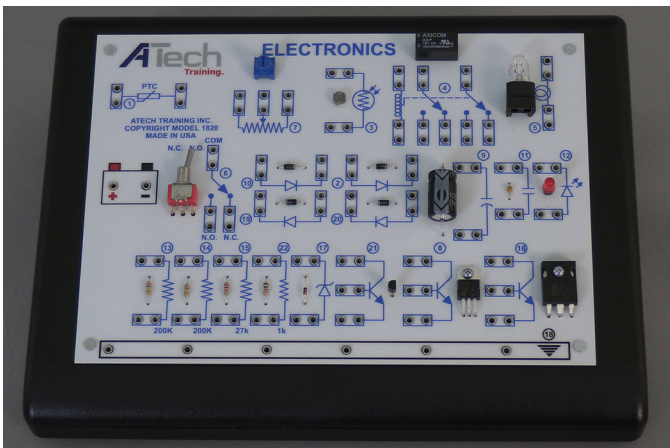

The Electronics (Model 1820) trainer is a hands-on study of basic automotive electronics. The trainer features real fixed components, wire terminals, 15-Volt power supply. Fault insertion capability with optional Keypad (Model 1802C) or with the Classroom Management Program (CMP) and CBI. Included is a USB drive containing the Student Manual , Instructor Guide and an on-site copy license to allow for the reproduction of instructional materials for use in the classroom.



Optional Storage Case available.

- Meter Usage (Volts, Ohms, Amps)
- Series, Parallel, and Series-Parallel Circuits
- Vehicle Automotive Circuits
- Service Information Schematics
- Troubleshooting Practice
- Optional Storage Case Available
- Competency Testing

Electrical & Electronic Systems

Electrical/Electronic



Interactive Keypad Model 1802C

The Interactive Keypad (Model 1802C) can interface with the ATech Electricity (Model 1810), Electronics (Model 1820), and Sensors and Actuators (Model 1830) trainers. It provides student interaction during electrical/electronic troubleshooting of “hidden” faults and student testing. Instructors can retrieve test scores/times and insert specific faults with the Interactive Keypad. The Interactive Keypad is necessary for interfacing as a means of data entry, student prompts, and operational display.

Electrical & Electronic Systems

Electrical/Electronic



The Electrical / PWM / Fault Trainer is designed to introduce the concepts of Electrical Fundamentals, Pulse Width Modulation (PWM) Actuator Control, and Fault Diagnosis. The trainer is compact, self-contained, and provides a PWM output to view the signal on an oscilloscope.

Electrical / PWM / Fault Trainer Model 2210

Components and Capabilities:

- Power supply providing 12VDC
- Four different value electrical loads
- ON / OFF switch with LED indicator
- Banana jacks for making wiring connections
- Connector wires in three colors
- Auxiliary jacks for testing external components
- Ground jack
- Fuse for circuit / device protection
- Four-position switch for inserting faults: (Open, High Resistance, Short to Ground, Short to Voltage)
- Faulted / non-faulted switch
- PWM (duty cycle) output control knob
- High / low frequency selector switch
- PWM output jack
- Optional Submounts and Storage Case available

Subject Areas:

- Voltage
- Current
- Resistance
- Power
- Voltage Drop
- Series Circuits
- Parallel Circuits
- Series-Parallel Circuits
- Ohm's Law Relationships
- Ohm's Law Calculations
- Pulse Width Modulation Control
- Circuit Operation
- Fault Diagnosis



Optional Storage Case Available.

This trainer is intended to provide instructors the flexibility to not only create their own circuits but to develop the corresponding measurement, diagnostic procedures as needed for Electricity, PWM, and Faulting.

Contact ATech for information on customizing this trainer for your needs.

Electrical & Electronic Systems

Electrical/Electronic



Applied Electrical Trainer Model 4810

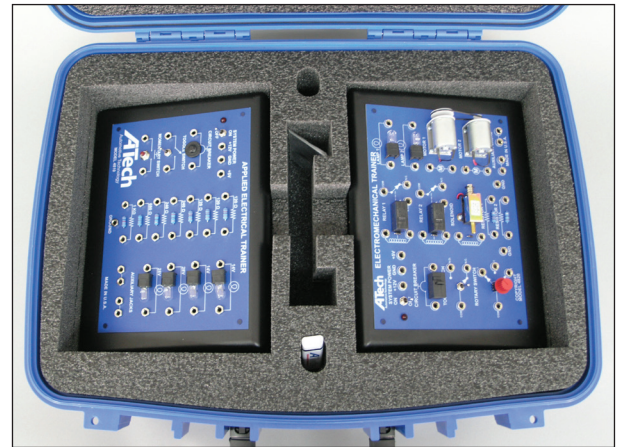

Optional Storage Case Available.



The Applied Electrical Trainer presents the study of electricity and electrical circuits. This training unit also has the flexibility to allow instructors to create their own circuits and/or tests for measurement and evaluation. Optional Submounts and Storage Case available.



The Applied Electrical Trainer contains the following components and capabilities:

- Connector wires in three colors
- Auxiliary jacks for optional submounts
- Includes Student Manual and Instructor Guide

- Voltage
- Current
- Resistance

- Series Circuits
- Parallel Circuits
- Series-Parallel Circuits

- Power
- Voltage Drop
- Diagnostic Testing

- Meter Usage Including Prefix Conversion
- Ohm's Law Relationships / Calculations

This training unit also has the flexibility to allow instructors to create their own circuits and/or tests for measurement and evaluation. Optional Submounts and Storage Case available.

Electrical & Electronic Systems

Electrical/Electronic



Optional Storage Case Available.

Electromechanical Trainer Model 4820



The Electromechanical Trainer presents the study of electrical and mechanical circuits. This training unit also has the flexibility to allow instructors to create their own circuits and / or tests for measurement and evaluation. Optional Submounts and Storage Case available.

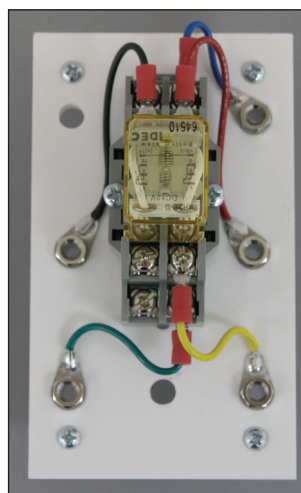

*Includes: Clear Case Relay & Socket
500-008-006*

The Electromechanical Trainer contains the following components and capabilities:

- Connector wires in five colors
- Auxiliary jacks for optional submounts
- Includes Student Manual and Instructor Guide

- Relay Operation
- Magnetic Fields
- Electrical Generator

- Power
- Voltage Drop
- Diagnostic Testing

- Series Circuits
- Parallel Circuits
- Series-Parallel Circuits

- Voltage
- Current
- Resistance

- Meter Usage
- Ohm's Law Relationships / Calculations

This training unit also has the flexibility to allow instructors to create their own circuits and/or tests for measurement and evaluation. Optional Submounts and Storage Case available.

Electrical & Electronic Systems

Electrical/Electronic

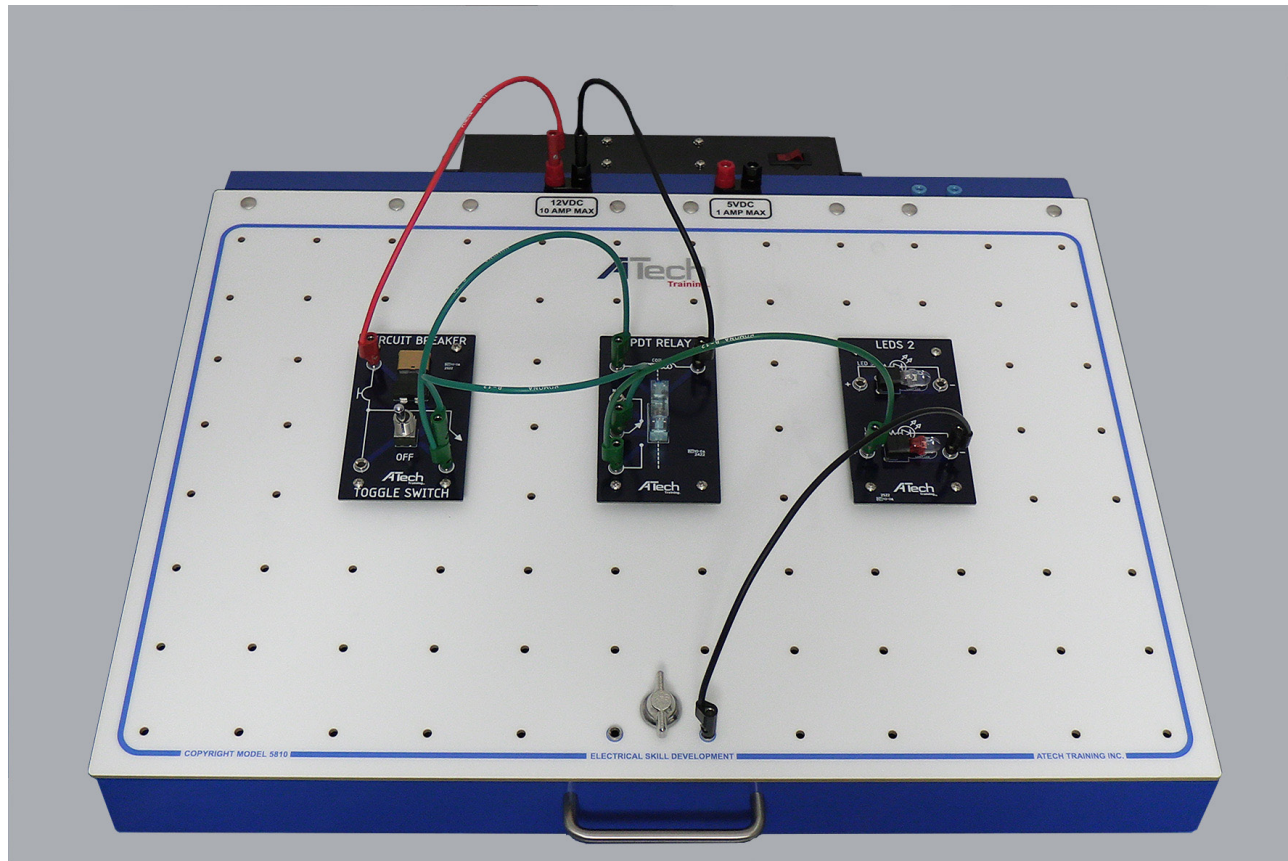

Electrical Skill Development Model 5810

Electrical Skill Development (ESD) provides an in-depth, hands-on study of automotive electricity and electronics by introducing electrical and electronic components mounted on submounts. Both serial and parallel circuits can be configured to perform the activities in the ESD courseware.

- Force sensitive resistor
- DC motor generator
- Precision temperature sensor
- Courseware included: Student Manual and Instructor Guide
- Optional submounts can be added to create customized circuits
- Clear relays (observe contact movement!)
- DC to AC voltage inversion

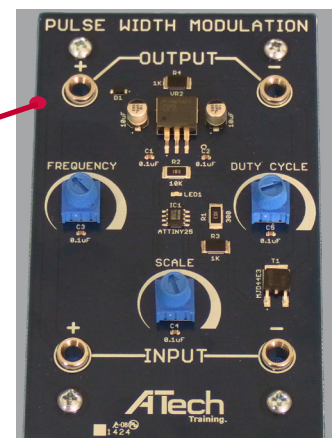
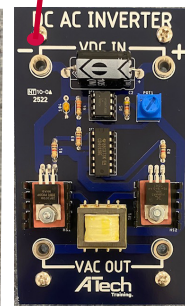
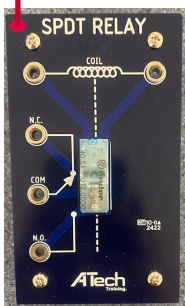

Pulse Width Modulation
500-009-001

Electrical & Electronic Systems

Electrical/Electronic



Electrical Skill Development Troubleshooting Model 5810TT

Electrical Skill Development Troubleshooting (ESDTT) provides an in-depth, hands-on study of automotive electricity and electronics. Allows for troubleshooting skill development and competency testing. The internal fault board offers different computer-controlled hard faults.

Both serial and parallel circuits can be configured to perform the activities in the ESDTT courseware.

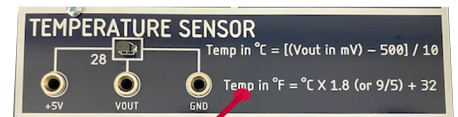
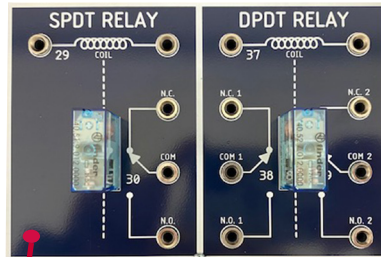

- Precision temperature sensor
- Clear relays (observe contact movement!)
- DC to AC voltage inversion
- DC motor generator
- Force sensitive resistor

- Optional submounts can be added to create customized circuits
- Courseware included: Student Manual and Instructor Guide
- Classroom Management Program (CMP) compatible
- Network display and storage of student's performance
- Fault insertion with keypad or A-Tech Lab System (ALS)



Electrical & Electronic Systems

Manufacturer Specialized Electronic Trainer

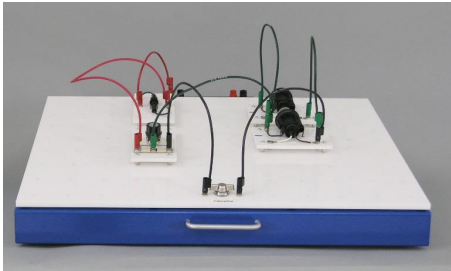

Caterpillar Fundamentals of Electrical Systems

Model 18002CAT

The Caterpillar Specialized Electronic Trainer (Model 18002CAT) offers students the hands-on study of basic automotive electricity and electronics as used in Caterpillar training centers. Included are a project board, power supply, component submounts, accessories, and an Operations Manual.

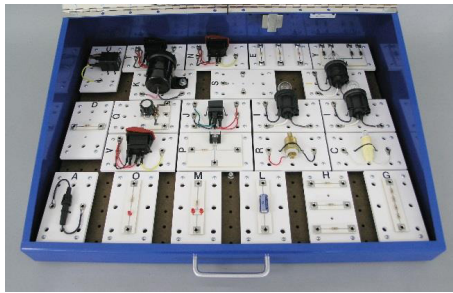

Honda Specialized Electronic Trainer

Model 18002H

The Honda Specialized Electronic Trainer (Model 1800H) offers students the hands-on study of basic automotive electricity and electronics as used in Honda training centers. Included are a project board, power supply, component submounts, accessories, and an Operations Manual and Honda Courseware

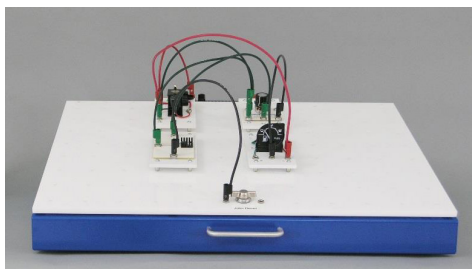
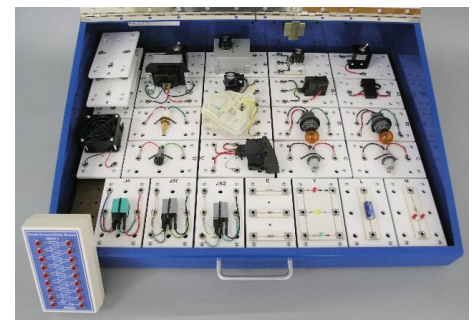
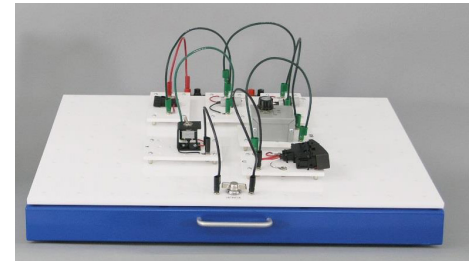

John Deere Specialized Electronic Trainer

Model 18002JD

The John Deere Specialized Electronic Trainer (Model 18002JD) offers students the hands-on study of basic automotive electricity and electronics as used in John Deere training centers. Included are a project board, power supply, component submounts, accessories, and an Operations Manual.

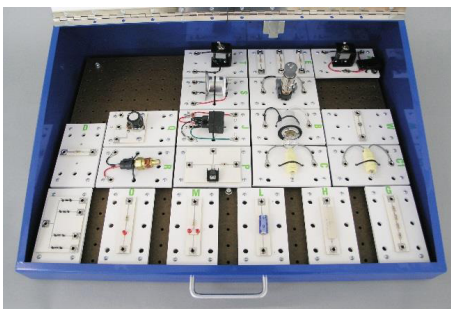

Electrical & Electronic Systems

Manufacturer Specialized Electronic Trainer

ATech was involved with the design and manufacturing of the electricity and electronic trainers currently used by General Motors, Chrysler, Ford, Nissan, Bosch, Honda and Volkswagen.

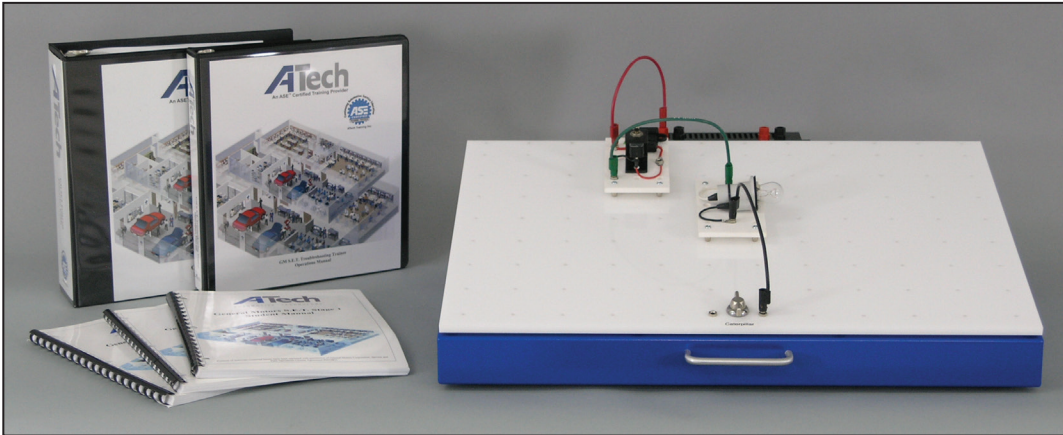

GM Specialized Electronic Training (S.E.T.) Program Model 18002TR

- The most widely used "OEM" Training System in the world
- Hardware design by ATech Training, Inc.
- Used by GM Training Centers and ASEP Schools
- Special configurations for John Deere, Caterpillar, Honda, Volkswagen and Volvo
- Selected vehicle components
- 12-Volt and 5-Volt DC power supplies included
- 12-Volt AC power supply included
- Complete "Factory" Courseware available
 - » Instructor Guide - Model 18002IG
 - » Student Workbook - Model 18002SM

"I'm impressed with ATech's superior dedication to quality training. It clearly shows in both product design and customer service. General Motors is pleased!"

*GM Service
Technology Group*

"This is the best automotive electronics training program anywhere!"

*Automotive Technology Instructor
Wheeling High School
Wheeling, IL*

Electrical & Electronic Systems

Manufacturer Specialized Electronic Trainer

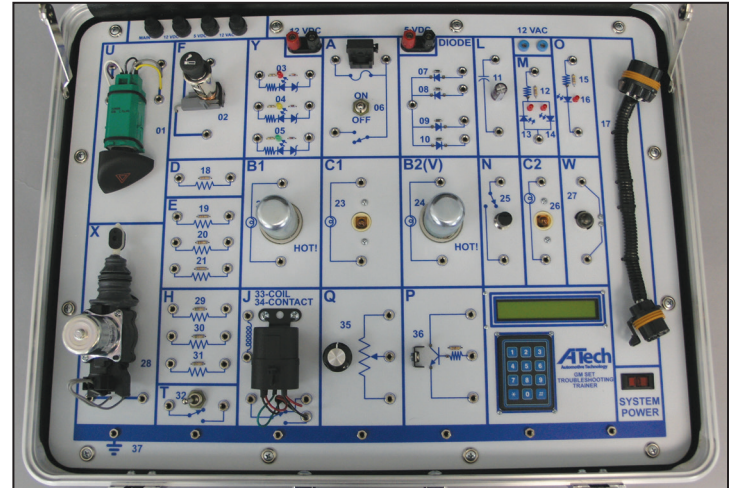
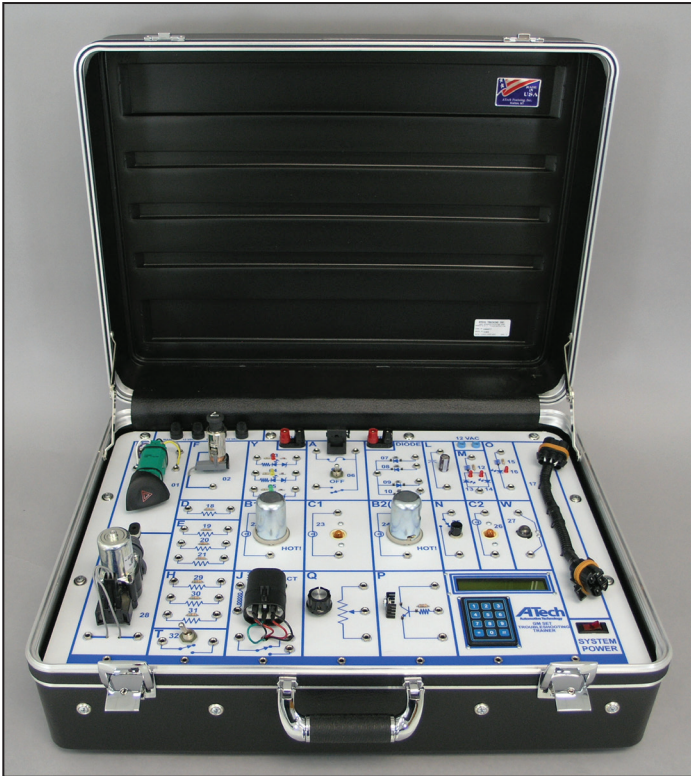

GM S.E.T. Troubleshooting Trainer Model 18002TT

Covers General Motors S.E.T. Electrical / Electronics Stage 1, 2, and 3:

- Provided in locking suitcase for security and portability
- Includes components for all three stages and original GM “faulted” components
- Local and network fault insertion
- Fault insertion selection by exercise number, “Example 3-2”
- Fault insertion selection by module
- Instructor can develop circuits and faults at component level
- Network display and storage of student’s performance
- Compatible with ATEch Lab System (ALS) and Classroom Management Program (CMP)

Electrical & Electronic Systems

S.E.T Optional Submounts

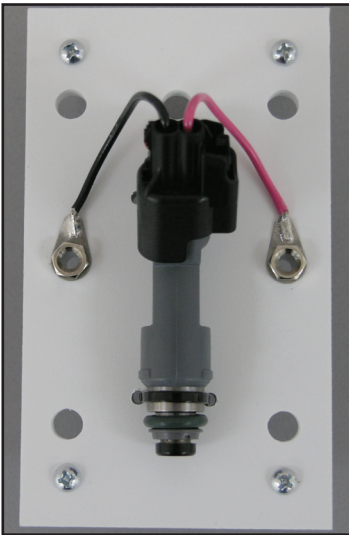

Fuel Injector
500-008-001

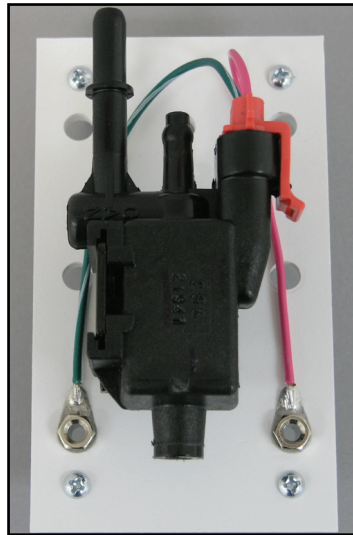

EVAP Purge Valve
500-008-002



Small Motor
500-008-003



Positive Thermal
Coefficient Resistor
500-008-004

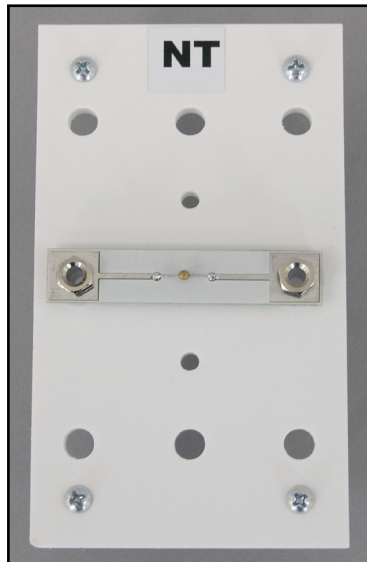

Negative Thermal
Coefficient Resistor
500-008-005

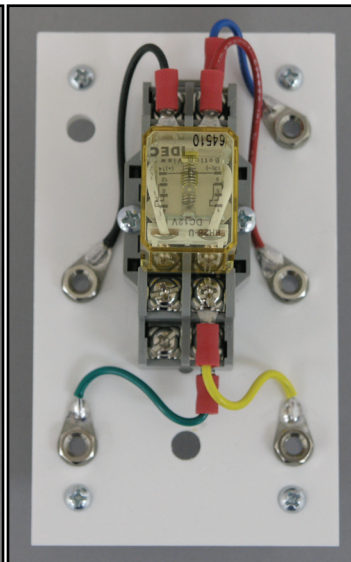

Clear Case Relay
and Socket
500-008-006



Double Pole Double
Throw Switch DPDT
500-008-007

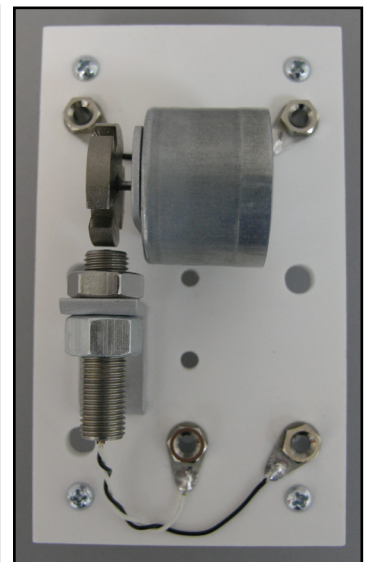

Variable Reluctor Sensor
500-008-008

Engine Performance

Engine Performance Trainers

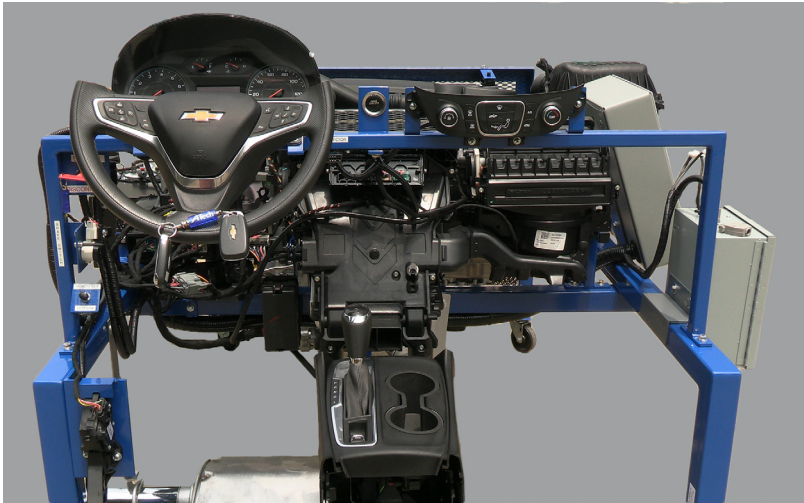

Engine Performance Trainer Model 650

GM • FORD

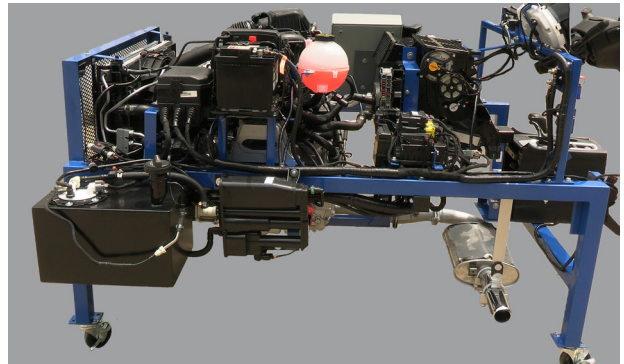
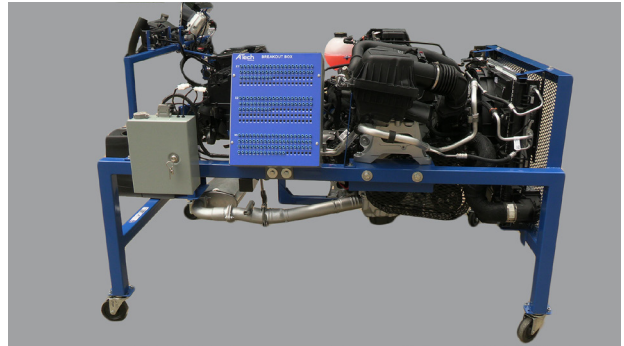

Features:

- Late-model recycled vehicle (front or rear wheel drive)
- Includes following automotive systems:
 - » Engine (4 Cylinder)
 - » Transmission (automatic or manual)
 - » Heat / Ventilation / Air Conditioning
 - » Electrical
 - » Exhaust
 - » Engine Cooling
 - » Emissions
- Includes an ATech Fault / Simulator Panel with multiple faulting options / features:
 - » Real-time voltage readouts or various selectable sensors
 - » Individual or multiple sensors are selectable for voltage substitutions
 - » Voltage adjustment potentiometers for each sensor
 - » Interactive demonstration / study of fuel control by oxygen sensor feedback
 - » Demonstrates catalytic convertor punch-through
 - » Investigates downstream oxygen sensor's control of fuel trim
- Data link connector (DLC) for scan tool diagnostics
- Breakout box with test points for every PCM pin
- Aids In developing real-world system skills and knowledge
- Performs actual service manual diagnostic procedures
- ASE task list and record keeping sheets
- Powder-coated frame mounted on casters for ease of mobility

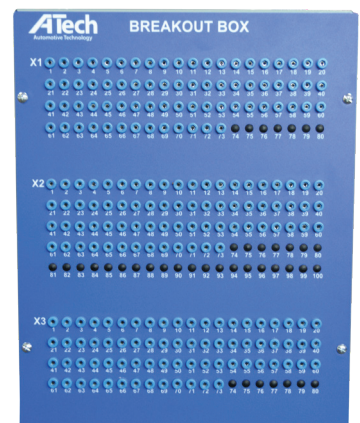
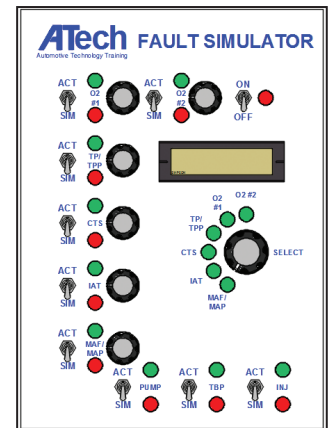

Engine Performance

Engine Performance Trainers

Engine Performance Trainer Model 650S

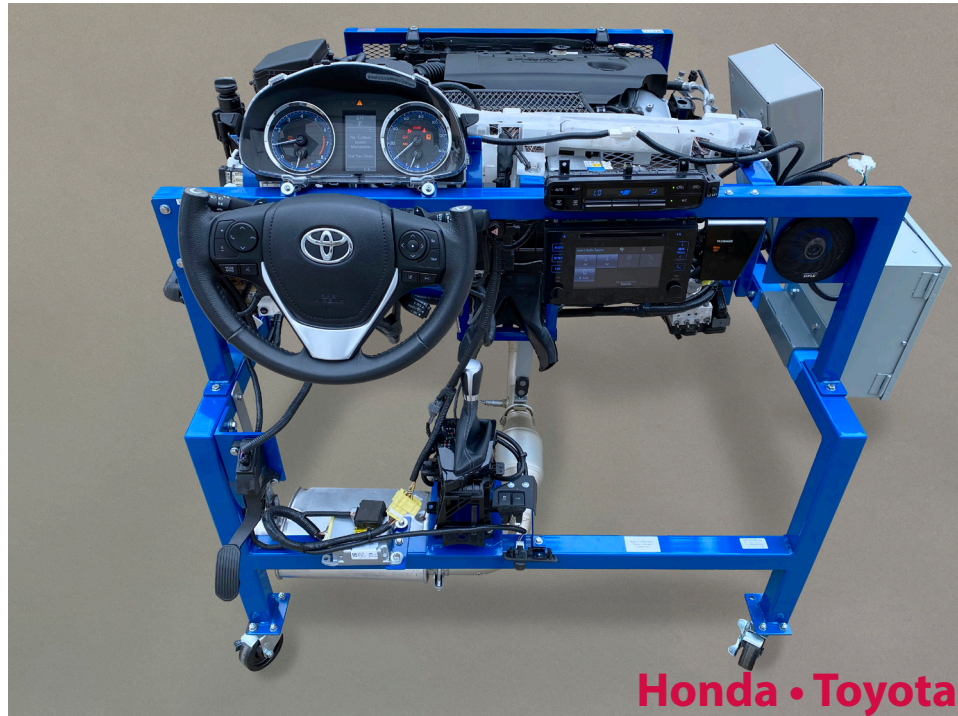

The Engine Performance Trainer presents the live operation and study of a fully functional engine and transmission. Available in 6 cylinder platforms, or special configuration.

Features:

- Fault/Simulator Panel
- Breakout Box to probe the wiring harness
- Data Link Connector (DLC) for scan tool
- Working HVAC system
- Engine Cooling
- Exhaust with full emissions
- Fuel cell with factory fuel pump
- Perform service manual diagnostic procedures
- ASE task list and record keeping sheets

Contact ATech Training, Inc. for engine availability

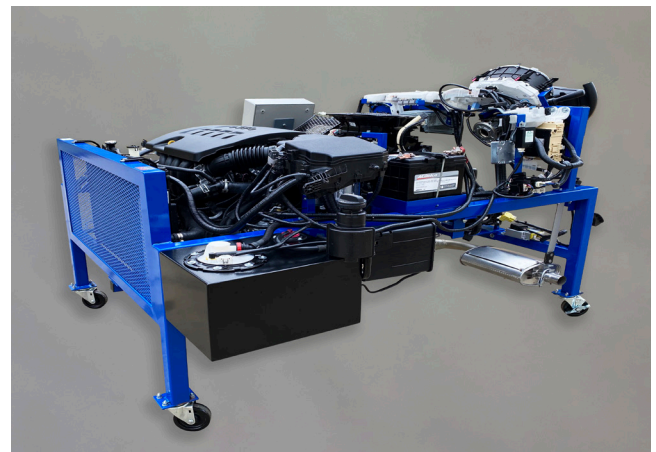
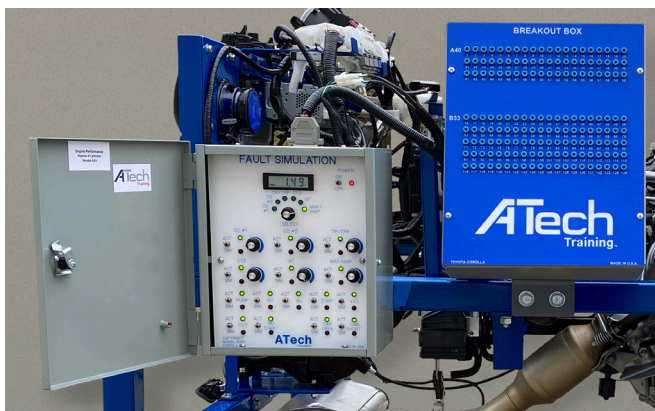

ATech Training, Inc
sales@atechtraining.com ♦ 1.888.738.9924

Engine Performance

Engine Performance Trainers



Bi-Fuel Engine Performance Trainer Model 650BF

Features:

- Late-model recycled vehicle (front wheel drive)
- Includes following automotive systems:
 - » Engine (gas and LPG1)
 - » Transmission (automatic)
 - » Heat / Ventilation / Air Conditioning
 - » Electrical
 - » Exhaust
 - » Engine Cooling
 - » Emissions
- Includes an ATech Fault / Simulator Panel with multiple faulting options / features
- Data link connector (DLC) for scan tool diagnostics
- Breakout box with test points for PCM pins
- Aids in developing real-world system skills and knowledge
- Performs actual service manual diagnostic procedures
- Powder-coated frame mounted on casters for ease of mobility

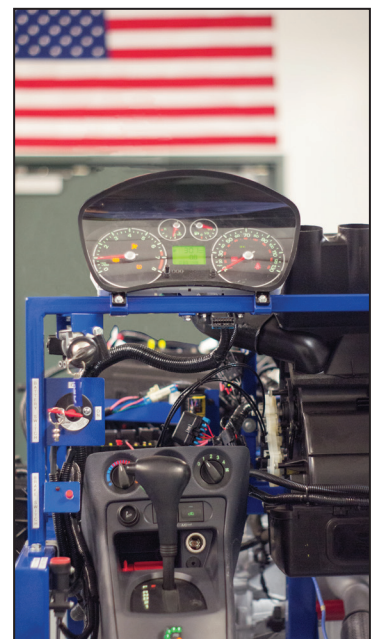

Engine Performance

Engine Performance Trainers

Engine Performance Troubleshooting Trainer Model 3601

The automotive fundamental programs include the Engine Performance Troubleshooting Trainer (model 3601). This platform will support models 3610, 3620 and 3630 computer-based courses and provides students with hands-on reinforcement.

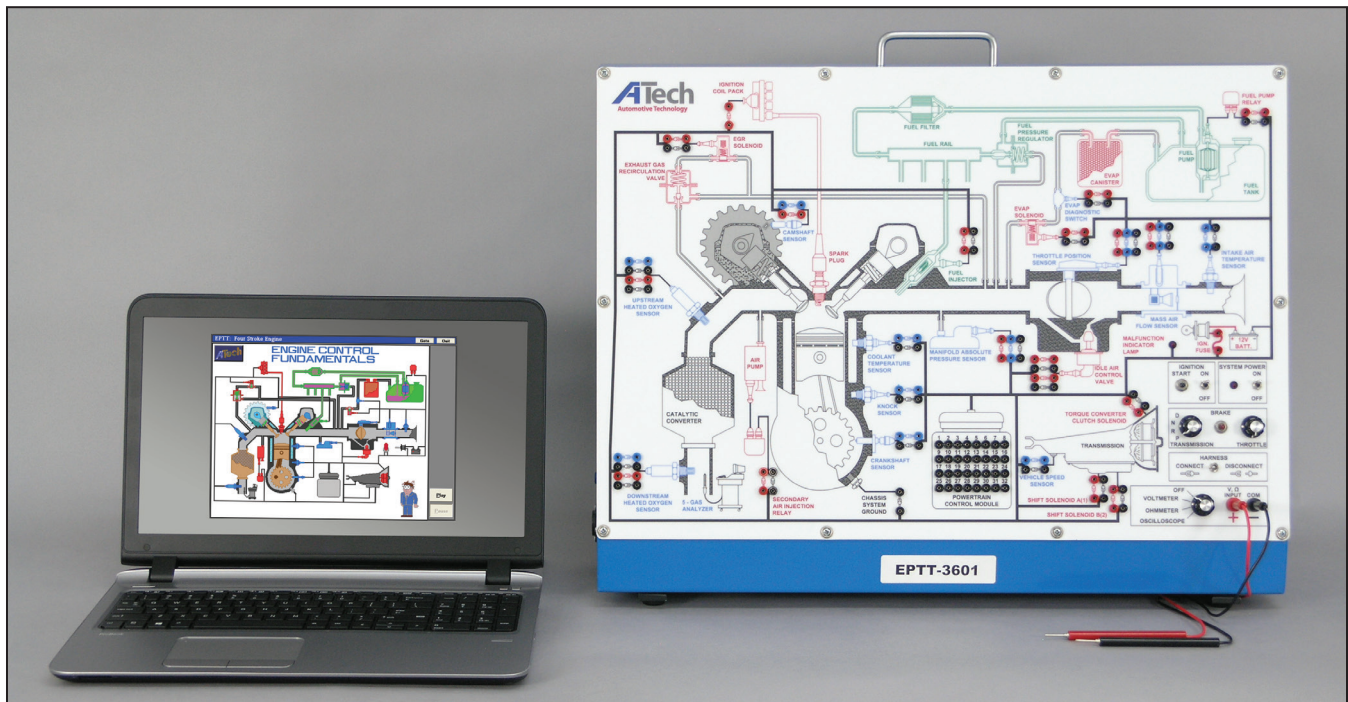
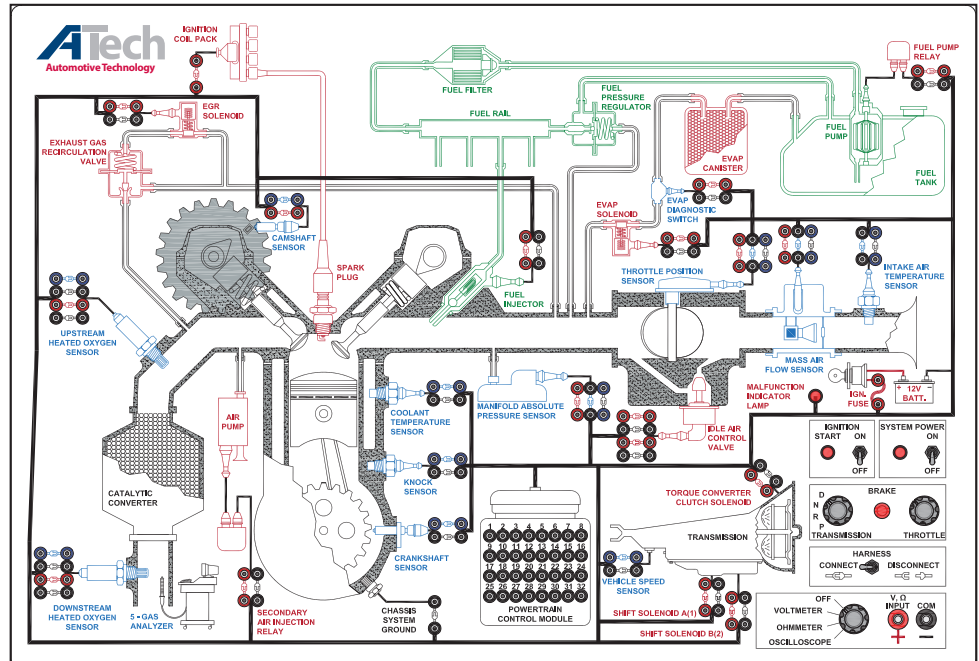

Computer-Based Programs

The #1 provider of Engine Performance Trainers offers computer-based simulation. ATech's automotive fundamental programs harness the power of computers to enhance the learning experience with animations of important concepts. Hands-on activities provide need-to-know reinforcement while computer-controlled diagnosis provides troubleshooting practice and competency testing. Keeps students highly motivated.

ATech Training, Inc

sales@atechtraining.com ♦ 1.888.738.9924

Engine Performance

Engine Repair

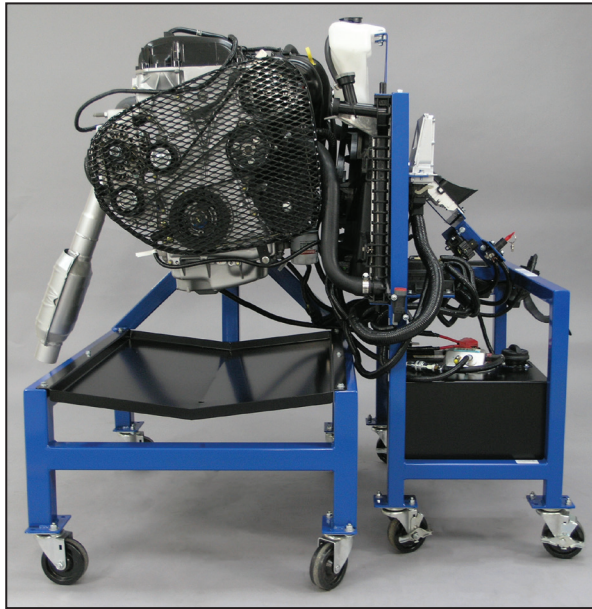

Engine Repair / Engine Start Cart Model 90/91

- Recycled Engine with rotating rebuild stand - model 90
- Engine Start Cart with necessary components to start engines - model 91
- Powder-coated frame
- ASE task list and record keeping sheets

GM • FORD

Automotive / Education Industry Proven

In addition to ATech's on-going support of public and private education, we work very closely with the automotive industry. Our users include:

AC Delco	Georgia Power	Pierce transit
Allied Signal	Goodyear Tire and Rubber	Porsche
American Honda Motor Company	Hyundai Motor America	Quaker State of Mexico
Atlanta Metro (MARTA)	Honda	Robert Bosch Corp.
Automatic Transmission Rebuilders	Job Corps Centers	Royal Guard Oman
AVIS Rental Car Company	John Deere Corp.	Santa Clara Valley Transit
B & B Electronics	Jordanian Army	Snap- On Tools
Bridgestone/Firestone	Kentucky DOT	SPX
Briggs-Weaver	Lincoln Technical Institute	Standard Motor Products
Canadian Military Forces	L.J. Technical Systems	Sun Tun
Caterpillar	Maserati	Toyota Material Handling
Chrysler	Mazda Automotive Corp	United States Air Force
Cincinnati Metro (SORTA)	Melior Institute	United States Government
Correctional Facilities	Mercedes-Benz Institute	United States Navy Research
CT Transit	Mitsubishi Automotive Co.	United States Postal Service
Delphi Delco Electronic System	Motorola Semi-Conductor Division	Universal Technical Intitute
Egyptian Air Force	Navistar	Volkswagen
Federal Mogual/Champion Spark Plug	Nissan	Volvo
Ferrari	No Lemon	Wyotech
Ferret Instruments	OTC	and many more...
Ford Motor Company	Pennsylvania DOT	
General Motors	Peruvian Army	

ATech Training, Inc

sales@atechtraining.com ♦ 1.888.738.9924

Page 46

Engine Performance

Evaporative Emissions System



Evaporative Emission System Model 640

The EVAP System presents the live operation and study of a late-model General Motors enhanced evaporative emissions (EVAP) system. The trainer will run the GM Service Bay EVAP Test using either its built-in scan tool or a Tech 2™. Realistic EVAP system faults, including system leaks, can be inserted via a built-in keypad, a local computer or via the optional ATech Lab System (ALS) to give students troubleshooting practice. Students follow manufacturer's diagnostic procedures when troubleshooting system faults. Diagnosing system leaks is enhanced by the clear hoses when using a smoke machine. Tech 2™ and smoke machine are NOT included with the trainer. Includes courseware.

Activities Include:

- Description and operation of the EVAP system
- Analyzing and interpreting schematics and manufacturer's troubleshooting and service procedures
- System diagnosing and troubleshooting
- Engine off natural vacuum (EONV) test demonstration
- Compatible with Classroom Management Program (CMP)

"I've used ATech Trainers for years. Very satisfied always..."

Vale Technical Institute
Blairsville, PA

Engine Performance

Fuel Pump/Injection

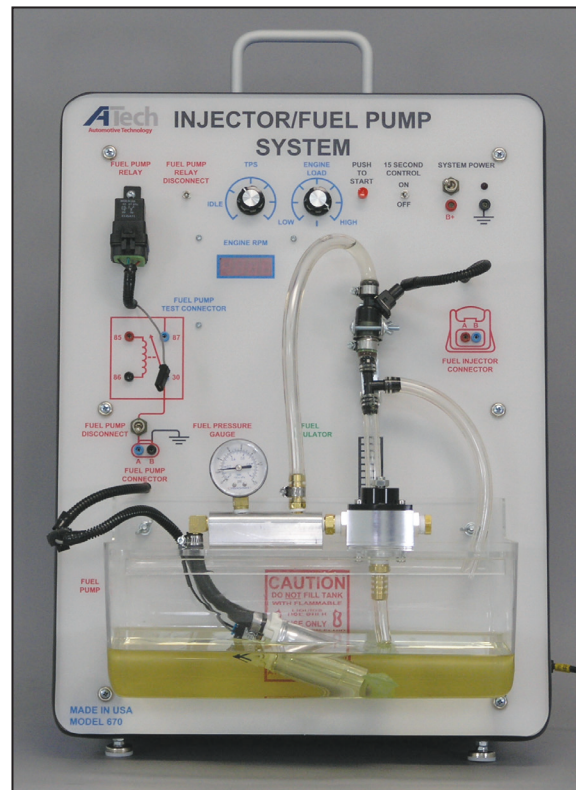

Injector / Fuel Pump System Model 670

- The Injector/Fuel Pump Trainer Demonstrates the Realistic Operation of Both a Fuel Pump Delivery System and a Fuel Injector
- Uses New Automotive Components Including the Fuel Pump, Fuel Injector, and Fuel Pump Relay
- Adjustable Controls for Both RPM and “Load” Control
- Has an Adjustable Fuel Pressure Regulator (with Pressure Gauge) for Easy Fuel Injection Volume Measurement
- A 15 Second Timer is Incorporated for Consistent Measurements at various RPM and Fuel Pressure Levels
- Speed Variable from 200 - 5,140 RPM
- Digital MultiMeter/Oscilloscope Test Points for the Fuel Injector, Fuel Pump Terminals, and the Fuel Pump Relay Control Circuit
- Internal 12V Power Supply
- Courseware is Included (Student Manual and Instructor Guide)

Engine Performance Ignition System

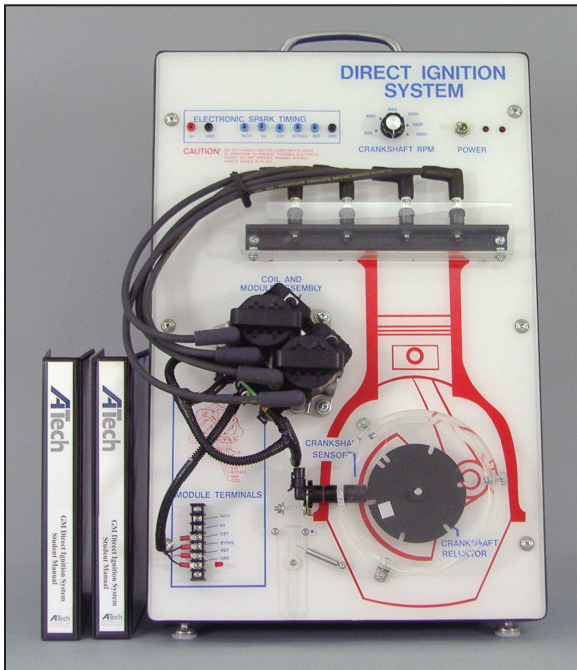

GM Direct Ignition System Faulted Model 1711F

- Used by GM Training Centers
- Live component operation
- Magnetic generator sensor type
- Realistic troubleshooting
- Courseware included
- Network / local fault insertion (Keypad required Model 1802C)

Integrated Electronic Ignition System Model 1792

- Coil on plug ignition system
- Real world system skills and knowledge
- Live component operation
- Crank and cam sensors
- Probe points for DMM or oscilloscope
- Courseware included
- Network / local fault insertion

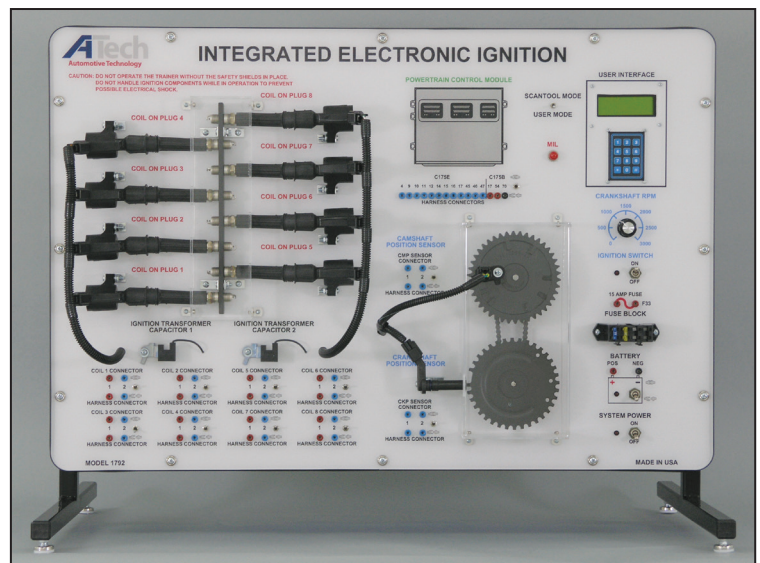

Engine Performance Ignition System

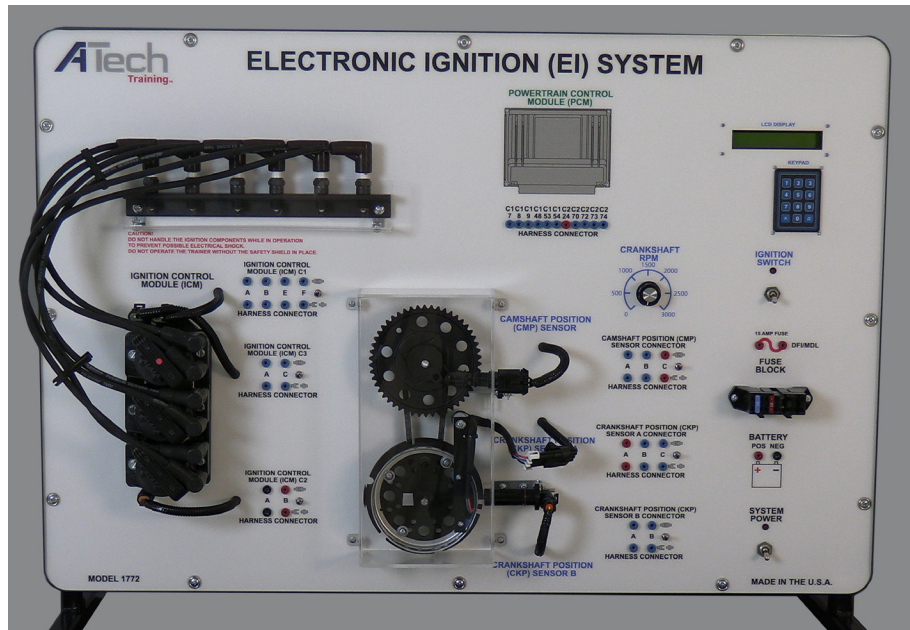

Electronic Ignition (EI) System Model 1772

Features:

- The Electronic Ignition (EI) System demonstrates the operation of a GM six-cylinder electronic ignition
- Uses actual automotive components including:
 - » Hall-Effect Crankshaft Position Sensor (CKP-A)
 - » Magnetic Generator Type Crankshaft Position Sensor (CKP-B)
 - » Hall-Effect Type Camshaft Position Sensor (CMP)
 - » Ignition Control Module
 - » Three Dual-Tower (Waste Spark) Coils
 - » 6 Spark Plugs and Spark Plug Wires
 - » 24 "Window" / 7X Crankshaft Wheel
 - » Camshaft Wheel
- Aids in developing real-world system skills and knowledge
- DVOM test points and harness disconnect switches for the following signals:
 - » Ignition Control Module Connectors 1, 2, and 3
 - » Crankshaft Position Sensor A
 - » Crankshaft Position Sensor B
 - » Camshaft Position Sensor
- Additional DVOM test points for:
 - » PCM
 - » Battery (12V) and Ground
 - » Fuse
- Speed variable from 0 - 3,000 RPM
- Faults can be inserted using the built-in keypad or using the Classroom Management Program (CMP) via the ATech Lab System (ALS)
- Internal 12V power supply
- Courseware is included (Student Manual, Instructor Guide, Service Manual Information)
- Connects with GM OBD II System - Model 2652

ATech Training, Inc
sales@atechtraining.com ♦ 1.888.738.9924

Engine Performance OBD II Trainers

This trainer offers a hands-on study of OBD II technology with complete powertrain control, OBD II monitors, standard diagnostic features and performance of trip / drive cycles.

GM OBD II System Model 2652



Student Response and Local Fault Insertion Panel

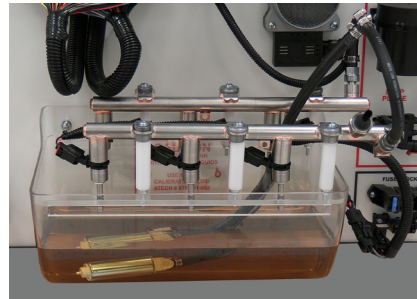

- Engine and transmission control
- Compatible with OBD II scan tools
- Performs GM OBD II drive cycle
- Enhanced diagnostics with code, engine protection and OBD II faults
- Interface with Electronic Ignition (EI) System (model 1772)
- Compatible with the ATech Lab System (ALS) and Classroom Management Program (CMP)
- Courseware and Service Manual information included

GM OBD II System (DRY) Model 2652 DRY



Dry Panel Option

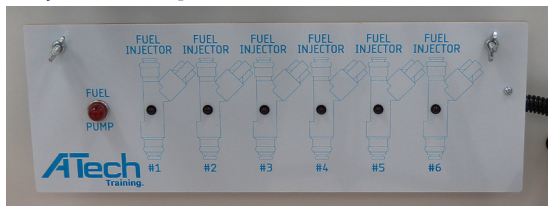

Dry Panel Option

- Fuel Injection and Ignition Trainer Interface: (Required for connection of ignition system to fuel injection trainer)
- GM OBD II - GM Electronic Ignition System Cable (model 2657)
- Dry Option: Simulated Fuel Injection / Pump - GM OBD II (Dry) - model 2652 DRY



Student Response and Local Fault Insertion Panel

Engine Performance Vehicle Technology Trainers



Automotive Technology Trainer Model 600

Features:

- The Automotive Technology Trainer or “car clip” is a late-model recycled front-wheel-drive vehicle
- Assists in the study and diagnosis of most automobile systems including:
 - » Engine Performance
 - » Electrical / Electronic
 - » Suspension / Steering
 - » Brake
 - » Heating / Air Conditioning
 - » Transmission
- Aids in developing real-world system skills and knowledge
- Performs actual service manual diagnostic procedures
- Includes an ATech Fault / Simulator Panel with multiple faulting options and features including:
 - » Real-time voltage readouts for various selectable sensors
 - » Individual or multiple sensors are selectable for voltage substitution
 - » Voltage adjustment potentiometers for each sensor
 - » Interactive demonstration / study of fuel control by oxygen sensor feedback
 - » Demonstrates catalytic convertor “punch-through”
 - » Investigates downstream oxygen sensor’s control of fuel trim
 - » And much more...
- Trainer sits on casters for ease of mobility
- ASE task list and record keeping sheets

GM • FORD



**Contact ATech Training for Other Engine
Availability (Model 600S)**

Engine Performance

Intermittent Fault Box Model 2112

Features:

The Intermittent Fault Box provides a means of faulting circuits in vehicles.

- Faulted circuits are connected through standard banana jacks. The following faults can be inserted:
 - » Open
 - » Incorrect Resistance
 - » Short to Ground
 - » Short to Voltage
- Fault duration switch
- Time between fault switch
- Hard and intermittent switch



"I am extremely grateful to be able to work with a company that goes above and beyond to help out their customers."

Diesel Equipment Technology Instructor

The Single Source for Automotive Educators

ATech's Programs Support

- ASE Task List
- Performance Based Education
- Career Tech Programs
- Transportation Programs
- Industry and Education Partnerships
- OEM Training

ATech's Engine Performance programs are at the heart of ATech's business - just as these systems are the heart of today's automobiles.

Electric Vehicle Technology

EV Trainer

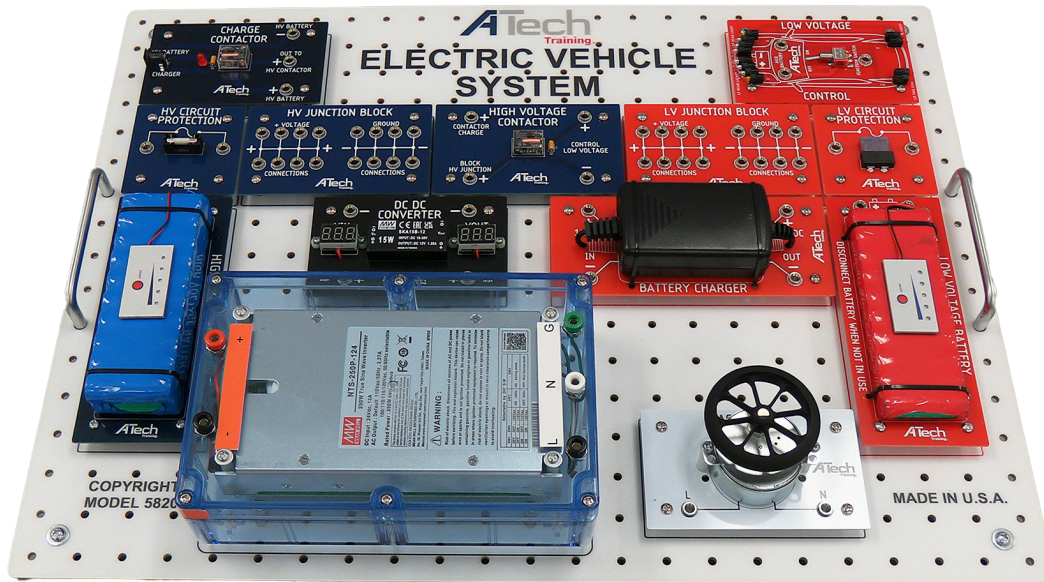

Electric Vehicle System Trainer Model 5820

The Electric Vehicle Systems Trainer was developed to introduce your students to EV systems with simulated components that are found on today's electric vehicles. With low voltage simulation, this trainer introduces students to the fundamentals without the danger of working with active high-voltage systems. It allows you to build mock EV circuits that will engage and challenge your students.

- HV Junction Blocks
- DC to AC Invertor
- DC to DC Converter
- Synchronous AC Drive Motor
- High Voltage Battery Pack
- Low Voltage Battery Pack
- Wall Charging Capable
- Contactors
- Battery Monitoring
- Low Voltage and High Voltage Systems Included
- Simulated High Voltage Components (24V MAX)

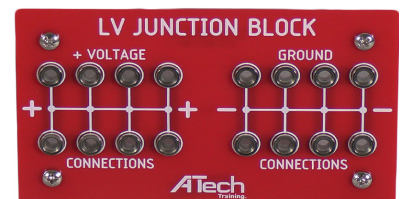
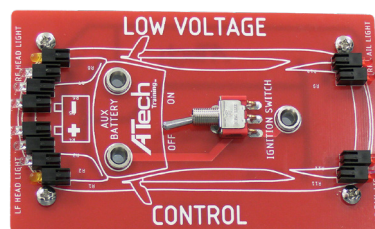
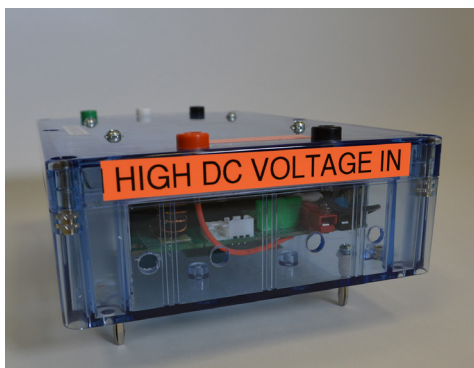
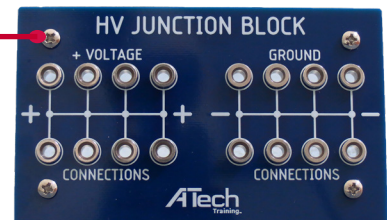
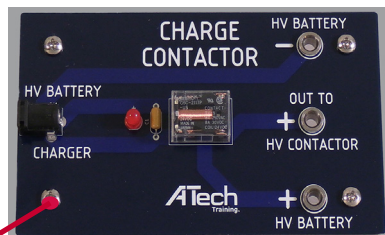

Electric Vehicle Technology Vehicle Technology Trainers



Vehicle Technology Trainer Model 610N

The Vehicle Technology Trainer uses a late model “recycled” vehicle. This trainer can be setup as a gas, diesel, electric, or hybrid option. This example shown with a Nissan Leaf.



Labeled Components Under the Hood

Clear Panels showing HV Wiring

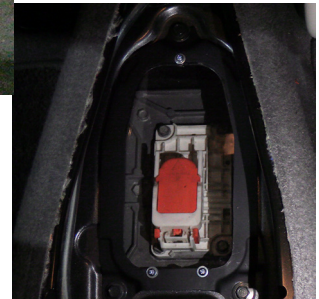

- Study and diagnose most automobile systems including:
 - » Engine Performance
 - » Electrical/Electronic
 - » Suspension/Steering
 - » Brake
 - » Heating/Air Conditioning
 - » Transmission
- Includes an ATECH Fault/Simulator Panel
- Perform actual service manual diagnostic procedures

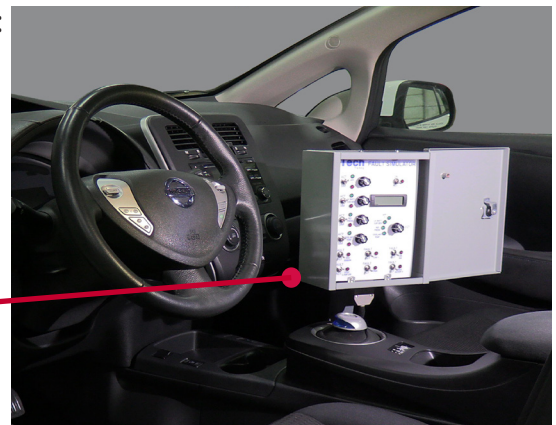

Electric Vehicle Technology Vehicle Technology Trainers



Vehicle Technology Trainer Model 610T

The Vehicle Technology Trainer uses a late model “recycled” vehicle. This trainer can be setup as a gas, diesel, electric, or hybrid option. This example shown with a Toyota Prius.

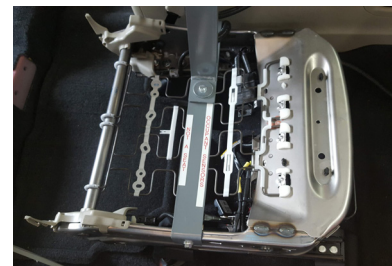

- Study and diagnose most automobile systems including:
 - » Engine Performance
 - » Electrical/Electronic
 - » Suspension/Steering
 - » Brake
 - » Heating/Air Conditioning
 - » Transmission
- Includes an ATech Fault/Simulator Panel
- Perform actual service manual diagnostic procedures



**Contact ATech Training, Inc. for other model availability
(Prius Prime (610PR))**

Electric Vehicle Technology

Hybrid Powertrain Cutaway Model 680 Special

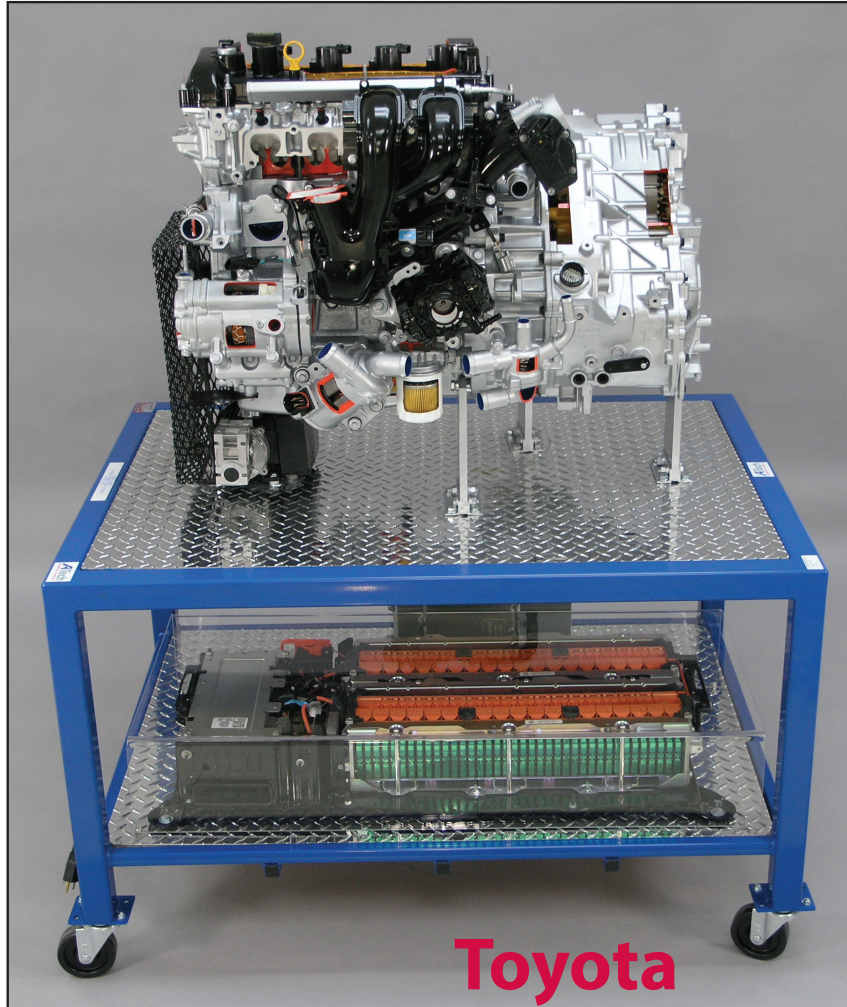

The Hybrid Cutaway (model 680 Special) is a complete Toyota Hybrid I-4 engine and planetary gear with sections cut away to expose the internal mechanical and electrical operating systems. Intake, exhaust, cooling, and lubrication systems are color coded to provide visual cues and allow for easy identification. This training unit includes an electric motor which rotates the engine at a low RPM to show the operation and interaction of the internal working components.

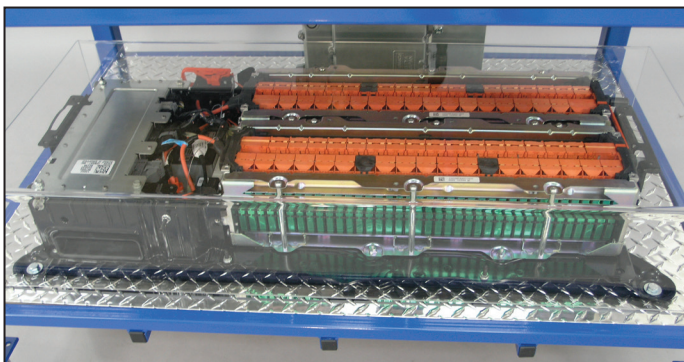

Diesel Technology

Diesel Engine Performance

Diesel Engine Performance Trainer Model 650D

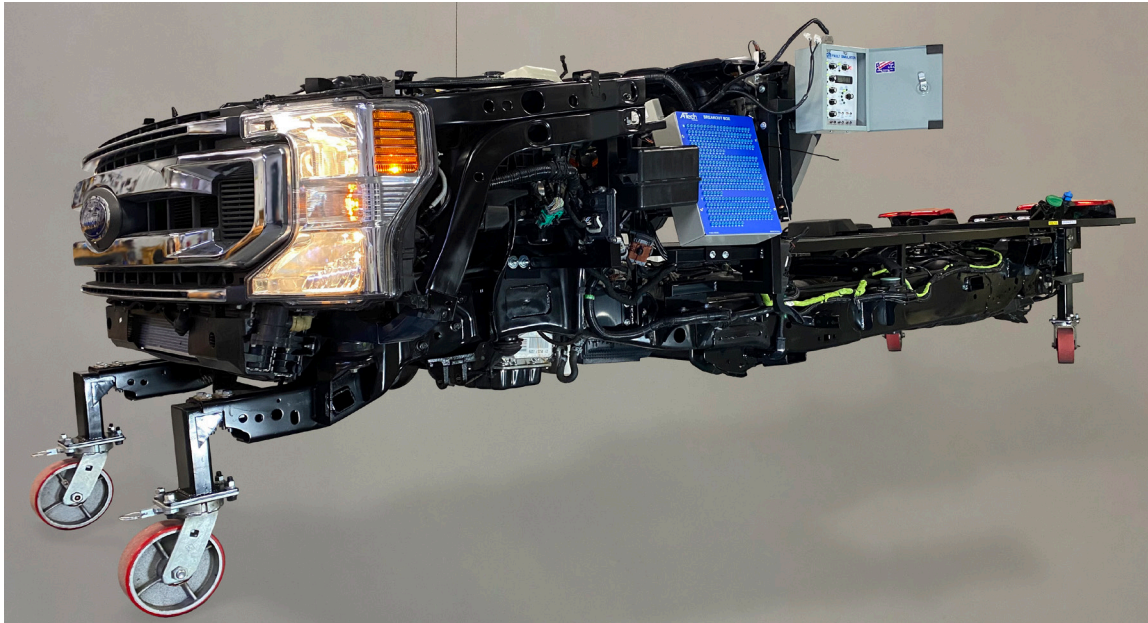

GM • FORD • VOLKSWAGEN

- New or remanufactured running engine
- Powder-coated frame
- Heavy duty casters
- Vibration control engine mounting
- Radiator cooling system with expansion tank
- Turbo intercooler
- Clutch drive fan with belt and pulleys
- Instrument panel
- Throttle control
- Diesel particulate filter (select models)

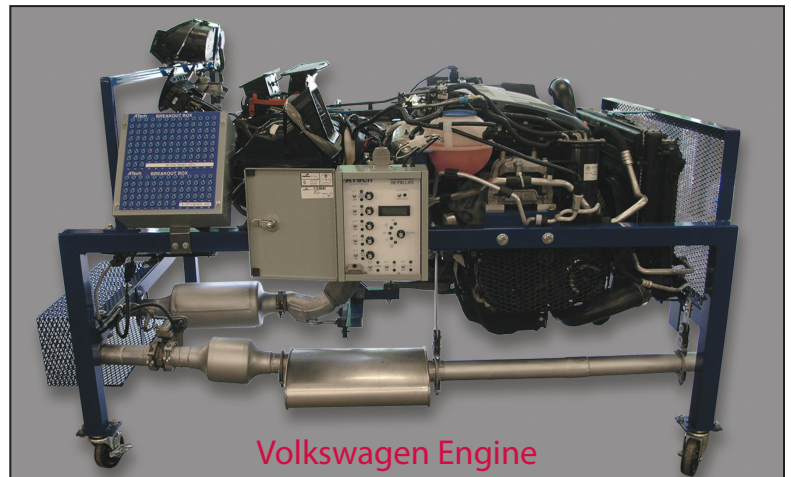

- Charging system
- Starting system
- Battery
- Fuel cell
- Electronic control module
- Electronic data link
- Urea SCR diesel exhaust fluid (select models)
- EGR (select models)
- Diesel oxidation catalyst (select models)

Contact ATech Training, Inc. for engine availability.

ATech Training, Inc
sales@atechtraining.com ♦ 1.888.738.9924
Page 58

Diesel Technology

Diesel Engine Performance

Diesel Engine Performance Trainer Model 650HD

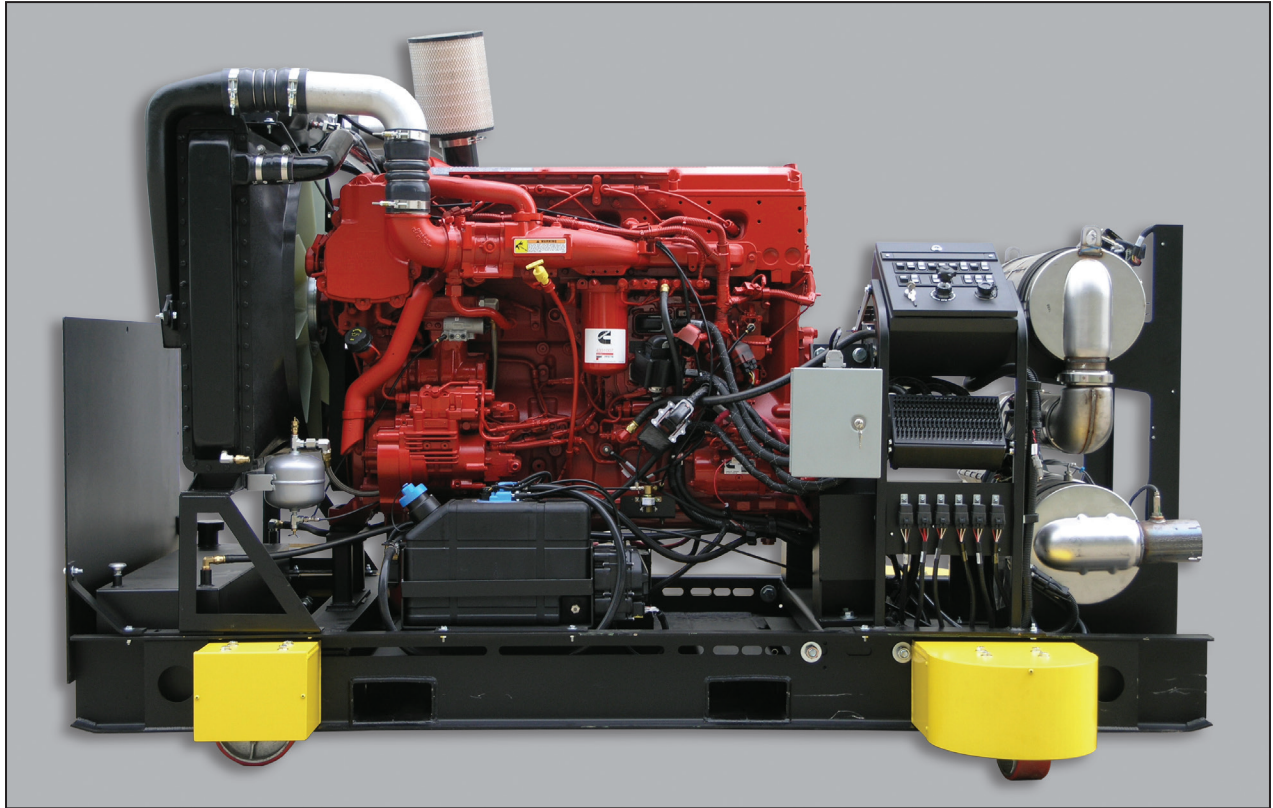

The Diesel Engine Performance Trainer (Model 650HD) presents the live operation and study of a fully functional diesel engine. The trainer has a new diesel engine and components depending upon customer request. The trainer includes fuel, air handling control, cooling, and exhaust after treatment systems.

Cummins ISB 6.7L • Cummins X15m 15L

Includes:

- High pressure common fuel rail engine
- Harness & batteries
- Instrument panel
- Fuel tank
- Electric fuel pump
- Fault insertion box
- Breakout box
- Diesel particulate filter (DPF)
- Selective catalytic reduction and dosing (SCR)
- Diesel oxidation catalyst (DOC)
- Exhaust gas recirculation (EGR)
- Variable geometry turbocharging (VGT)



Diesel Technology Diesel Technology Trainer

Diesel Technology Trainer Model 600D



GM • FORD

The Diesel Technology Trainer (Model 600D) presents the live operation and study of a late-model diesel pickup truck. It provides an advanced level of instruction by duplicating actual on-vehicle troubleshooting procedures. Requires 12VDC automotive batteries (included).

- Diesel particulate filter system (DPF)
- Has a fully functional engine, transmission, front brake system (rear lines are sealed), steering system, suspension system, fuel injection system, glow plug system, emission control, instrument panel, front and rear lighting system, and a air conditioning system
- ATech Fault / Simulator Panel for inserting realistic faults into the system
- Compatible with actual service manual test procedures
- Performs DPF regeneration with scan tool
- Portable via rolling casters
- Urea SCR diesel exhaust fluid (select models)
- EGR (select models)
- Diesel oxidation catalyst (select models)

Contact ATech Training, Inc. for engine availability.



Diesel Technology

Diesel Brakes (Air Brake System)

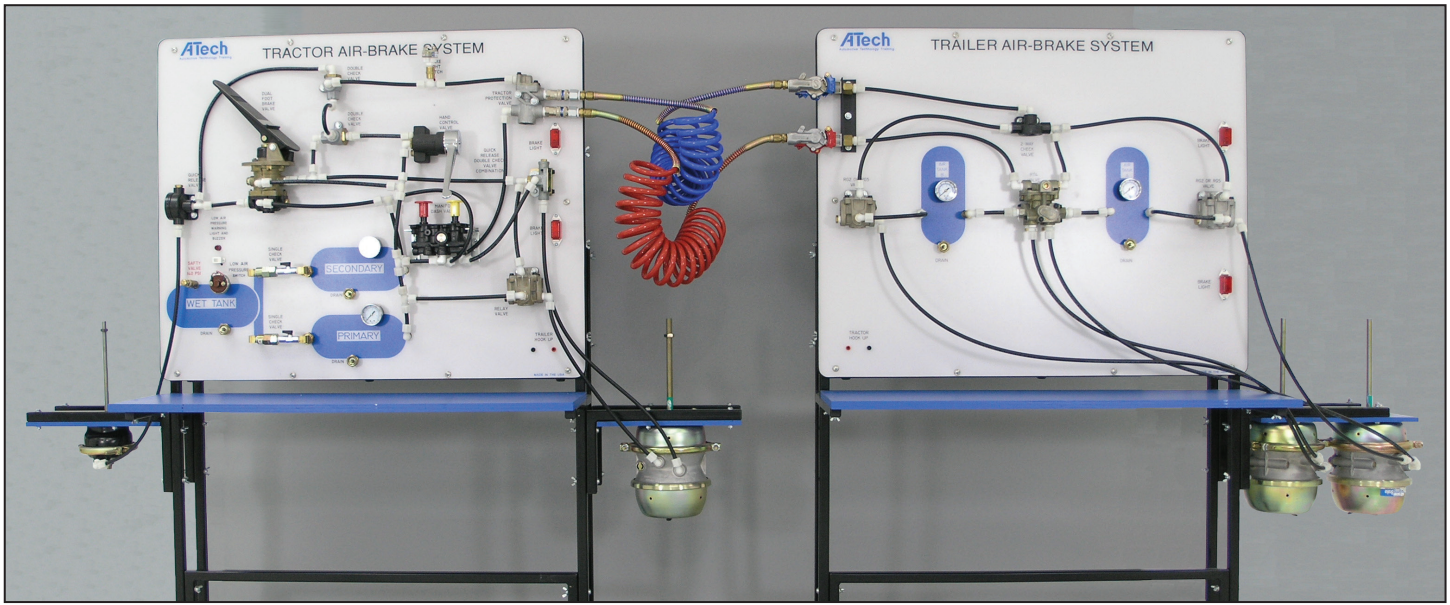

Tractor (Model 6410) and Trailer (Model 6420) Air-Brake Systems

Air-Brake Components Include:

- Low Pressure Warning Light and Buzzer
- Safety Valve
- Single Check Valves
- Brake Light Switch
- Double Check Valve
- Control Valve
- Relay Valve
- Spring Brake
- Tractor Protection Valve
- Service and Emergency Glad Hands
- RT2 Valve
- Quick Release & Double Check Valve Combination
- Low Pressure Indicator Switch
- Drain Valves - Manual
- Air Gauge
- Quick Release Valve
- Dual System Foot Brake Valve
- Spring Brake Valve
- Hand Control Valve
- Service Brake Chamber
- Manifold Dash Valve
- RT4 Valve
- D.O.T. Air-Brake Lines

The ATech Air-Brake System allows Demonstrations of:

- Compressor Failure
- Secondary Tank Failure
- Park Brake Apply and Release
- Tractor to Trailer Hook-up
- Primary Tank Failure
- Normal Brake Operation
- Trailer Braking (Hand Control Valve)
- Trailer Air Supply and Evacuate

The Air-Brake Systems are complete programs for presenting the real-world operation and study of Three Axle and Tractor / Trailer Air-Brake Systems. The trainers demonstrate FMVSS 121 Air-Brake Systems.

*** Courseware included with Models 6410 & 6430 only.**

Diesel Technology

Diesel Brakes (Air Brake System)



**Air-Brake System 3 Axle
Model 6430**

Air-Brake Components:

- Low Pressure Warning Light / Buzzer
- Low Pressure Indicator Switch
- Safety Valve
- Drain Valves - Manual
- Single Check Valves
- Air Gauge
- Brake Light Switch
- Quick Release Valve
- Double Check Valve
- Dual System Foot Brake Valve
- Control Valve
- Spring Brake Valve
- R12 Relay Valve
- R14 Relay Valve
- Spring Brake
- Service Brake Chamber

The ATech Air-Brake System allows System Demonstrations of:

- Compressor Failure
- Primary Tank Failure
- Secondary Tank Failure
- Normal Brake Operation
- Park Brake Apply and Release

Courseware Includes:

- Operations Manual
- Modern Diesel Technology
 - » Brakes, Steering & Suspension Systems Manual
- Modern Diesel Technology
 - » Brakes, Steering & Suspension and Hydraulics Job Sheets Manual
- USB Flash Drive Containing:
 - » Instructor's Guide - Modern Diesel Technology: Brakes, Suspension & Steering Systems
 - » Bendix Workbook - Air-Brake Systems Workbook
 - » Handout - Bendix Air-Brake Systems Workbook
 - » Troubleshooting Sheet
 - » The Air-Brake Handbook

The Air Brake System needs an external compressed air supply of 90 to 140 PSI and a standard 110 VAC electrical supply.

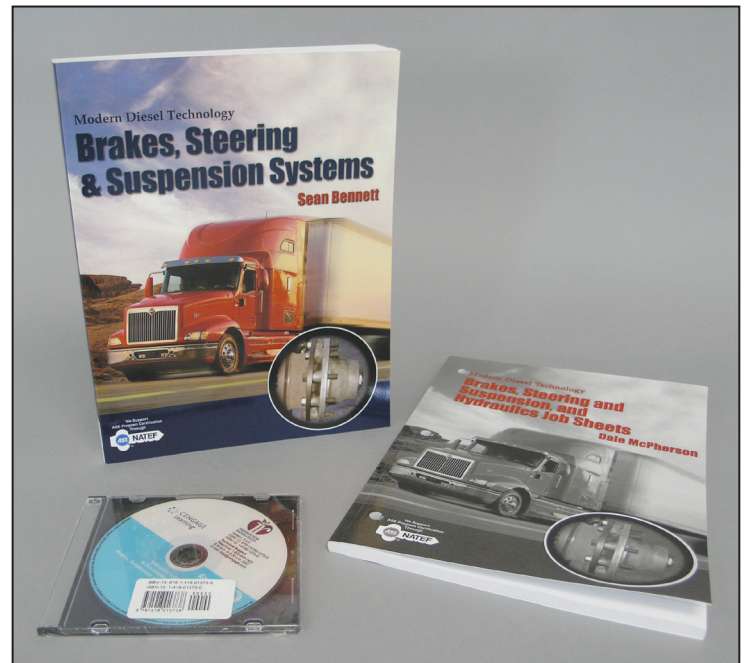

Air-Brake System Courseware
*** Included with models 6410 & 6430 only**

ATech Training, Inc
sales@atechtraining.com ♦ 1.888.738.9924

Diesel Technology

Diesel Engine Repair



- Recycled Engine with rotating rebuild stand - Model 90
- Engine Start Cart with necessary components to start engines - Model 91
- Powder-coated frame
- ASE task list and record keeping sheets

Diesel Engine Repair Trainer Model 90D

The Engine Repair (Model 90) trainer is designed for hands-on experience in disassembling and rebuilding automobile engines. Engine is mounted on a powder-coated frame constructed of square steel tubing and is portable with rolling casters. The stand allows the engine to be rotated 360° and includes a metal pan to catch oil leaks.

The Engine Start Cart (Model 91) trainer provides starting and testing capabilities for the Engine Repair (Model 90) trainer (sold separately). Start cart components are mounted on a powder-coated frame constructed of square steel tubing. Cart is portable with rolling casters.

Diesel Engine Start Cart Model 91D

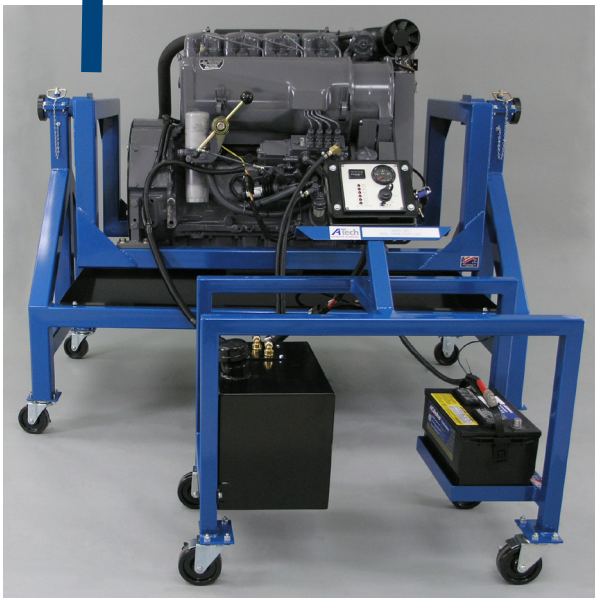



A Tech's CMP provides instructors the ability to easily manage their classroom of A Tech training equipment and Computer-Based Instruction software.

- Track Student Activities
- Hard & Intermittent Fault Insertion
- "Real time" Class Monitoring

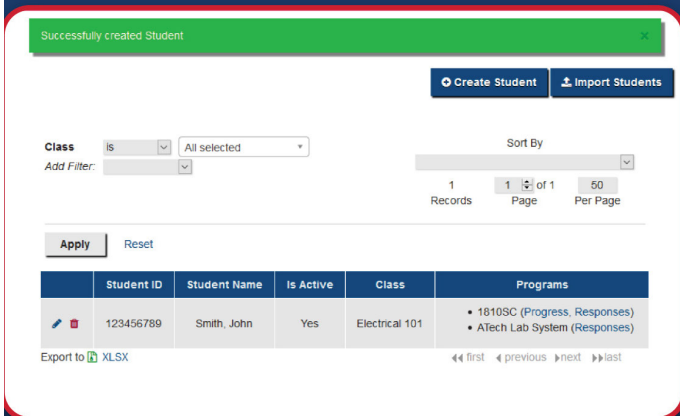
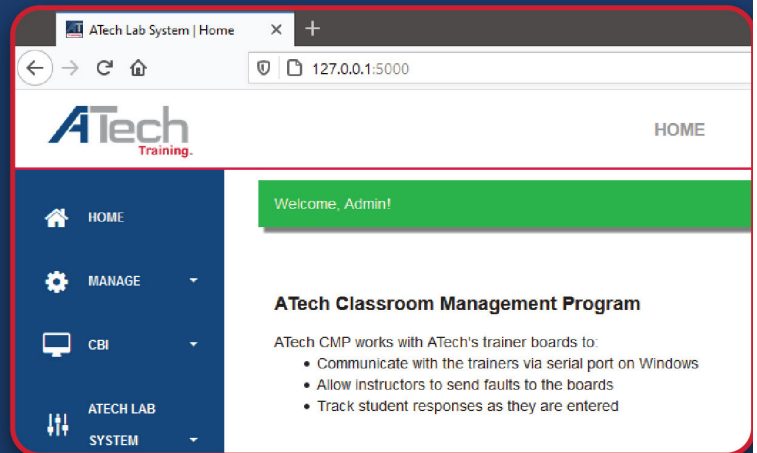

Control student access

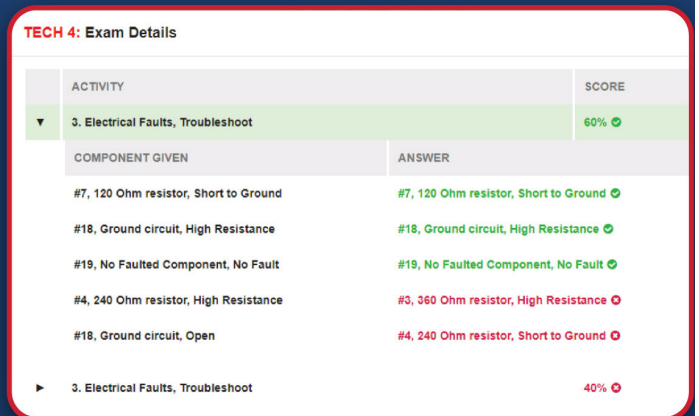

View student performance

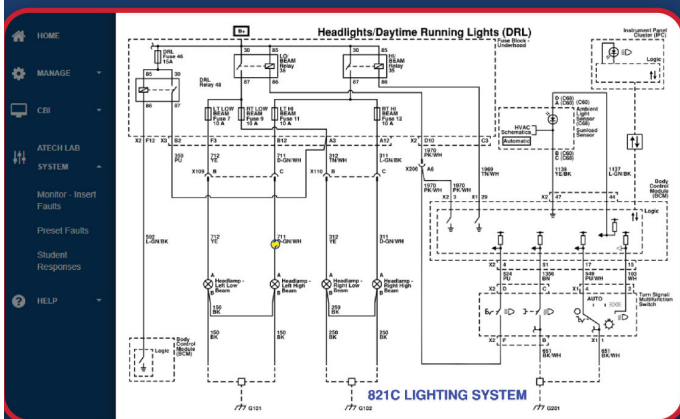

Wiring schematics

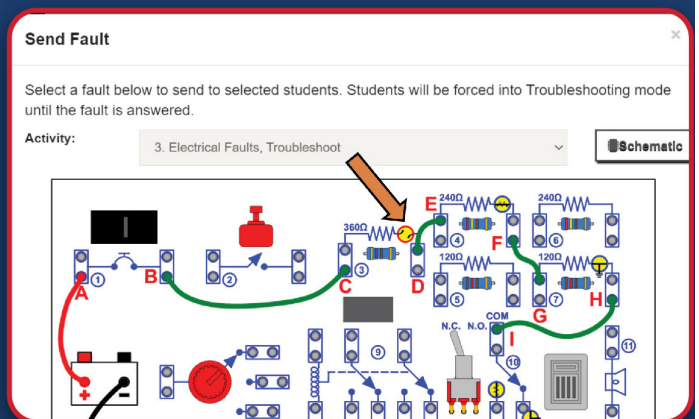

Insert troubleshooting faults

System Requirements:

- Windows 10/11 Professional or Enterprise
- Browser Interface (Chrome or Firefox)

12290 Chandler Drive
Walton, Ky 41094

A Tech Training.com
sales@atechtraining.com

1.888.738.9924

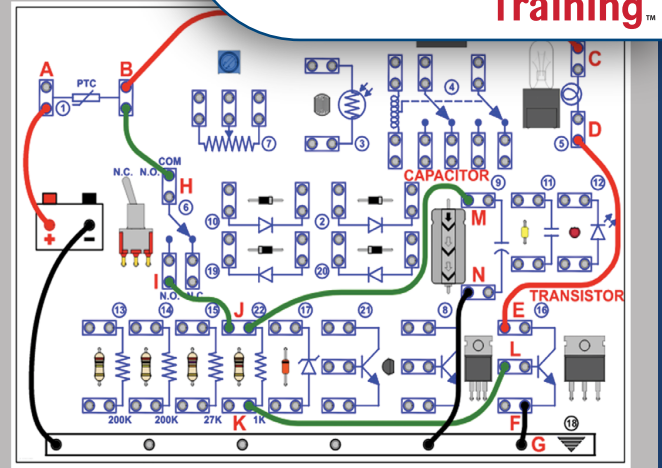
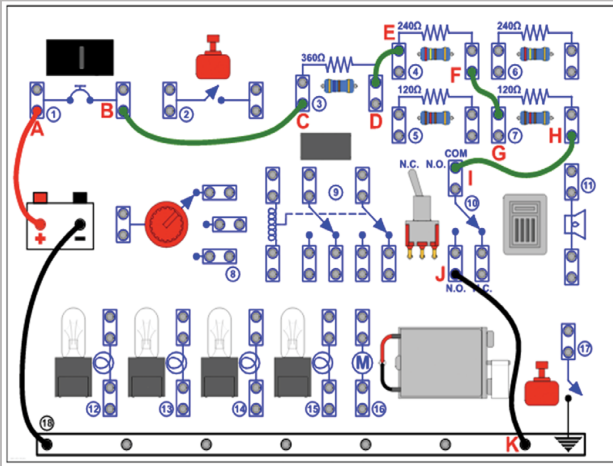

Electricity Program (1810SC)

Electronics Program (1820SC)

Electricity Program (1810SC) Activity List

- Activity 1 Electrical Components
- Activity 2 Voltage, Current, Meter, & Series Circuit
- Activity 3 Electrical Faults/Troubleshooting
- Activity 4 Ohm's Law & Parallel Circuit
- Activity 5 Relay and Circuit, Test Light
- Activity 6 Horn Circuit, Relay #2, Jumper
- Activity 7 Switches, Circuit Breaker, Short Finder
- Activity 8 Tail and Brake Light Circuit
- Activity 9 Starter Motor Circuit
- Activity 10 Turn Signal Circuit
- Activity 11 Ignition Key Warning Circuit
- Activity 12 Electric Cooling Fan Circuit
- Activity 13 Brake Warning Circuit
- Activity 14 Heater Blower Circuit
- Activity 15 Headlight Circuit
- Activity 16 Dome Light Circuit

Electricity Program (1820SC) Activity List

- Activity 1 Polarity
- Activity 2 Digital Multimeter
- Activity 3 Diode Fundamentals
- Activity 4 Diode as a Rectifier
- Activity 5 Light Emitting Diode (LED)
- Activity 6 Clamping Diode
- Activity 7 Zener Diode
- Activity 8 Transistor Basic
- Activity 9 Transistor Circuit
- Activity 10 Transistor as Amplifier
- Activity 11 Capacitors
- Activity 12 Photo Resistor
- Activity 13 Combination Electronics

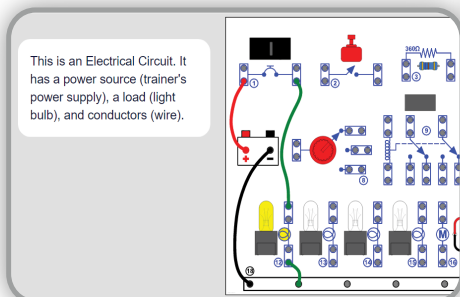

Self-paced activities

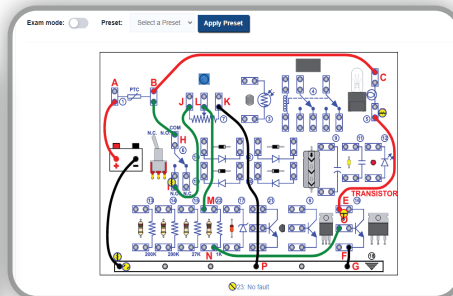

Troubleshooting

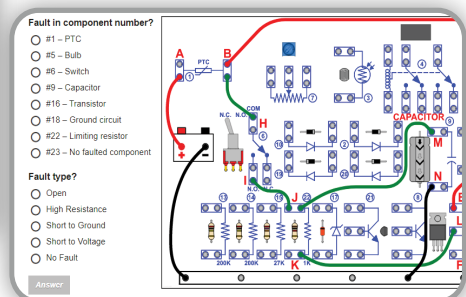

Exam modes

- Animations & interactive questions to enhance learning
- 20 to 40 hours of instruction

Computer-Based Instruction

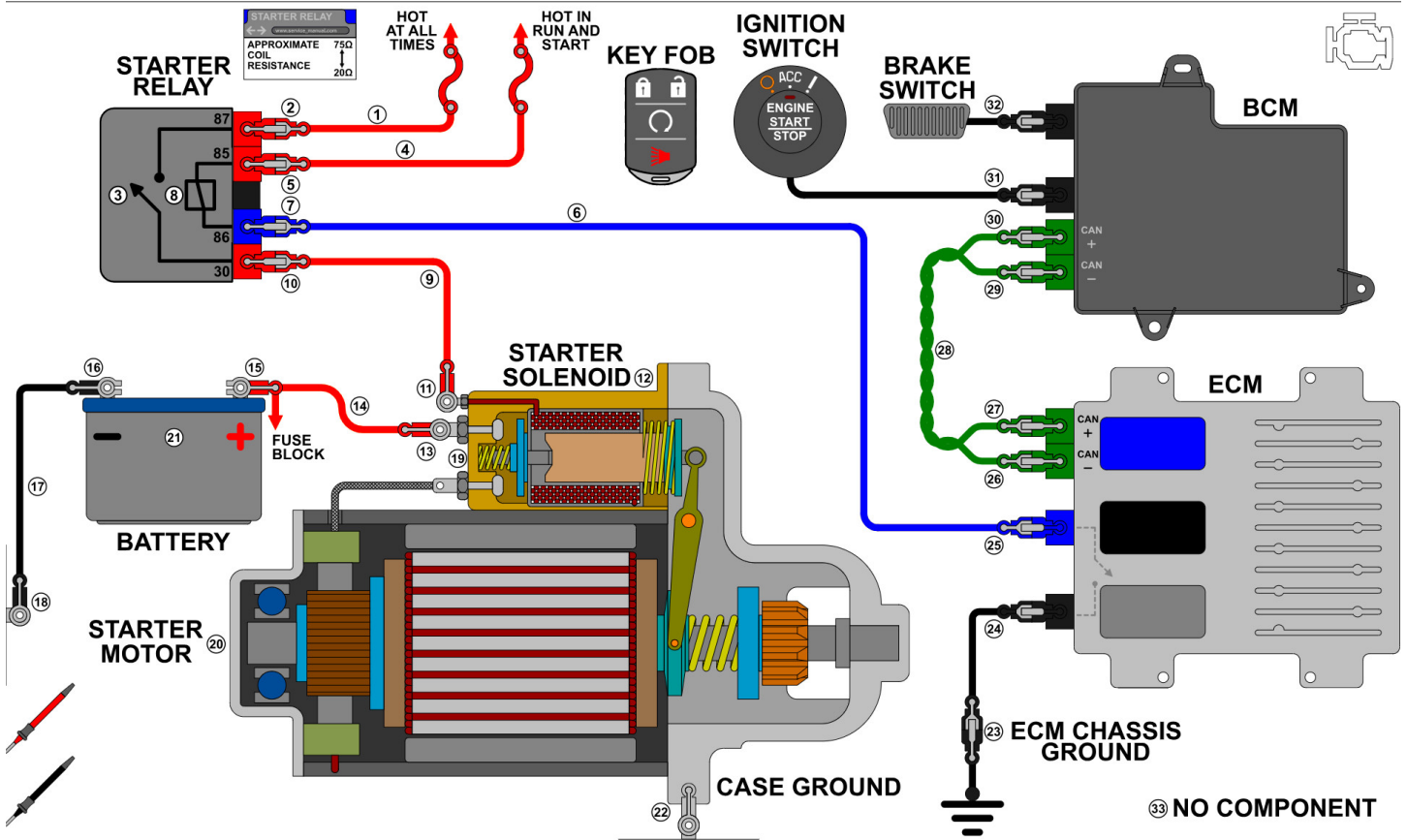

Starter System Troubleshooting - Model 2815SC

The Starter Troubleshooting software is based on a newer starting system and presents the basic concepts of troubleshooting a starter motor circuit. The key element in improving or developing diagnostic skills is to allow the student to follow the logical troubleshooting process without being distracted by hunting for wires, connectors, and other components.

- 57 Potential Faults
- Types of Troubleshooting Faults:
 - » Open Circuits
 - » High Resistance
 - » Short to ground
 - » Short to Voltage
 - » Shorted no-fault conditions
- Built-In DMM, Battery Load Tester, and Scan tool

Instructors can tailor students learning experience by allowing students to work in standard mode allowing measurements on both sides of a connector or advanced mode allowing measurements on one side. Using the Classroom Management Program (CMP) Instructors can insert faults, monitor student progress and review responses

Computer-Based Instruction

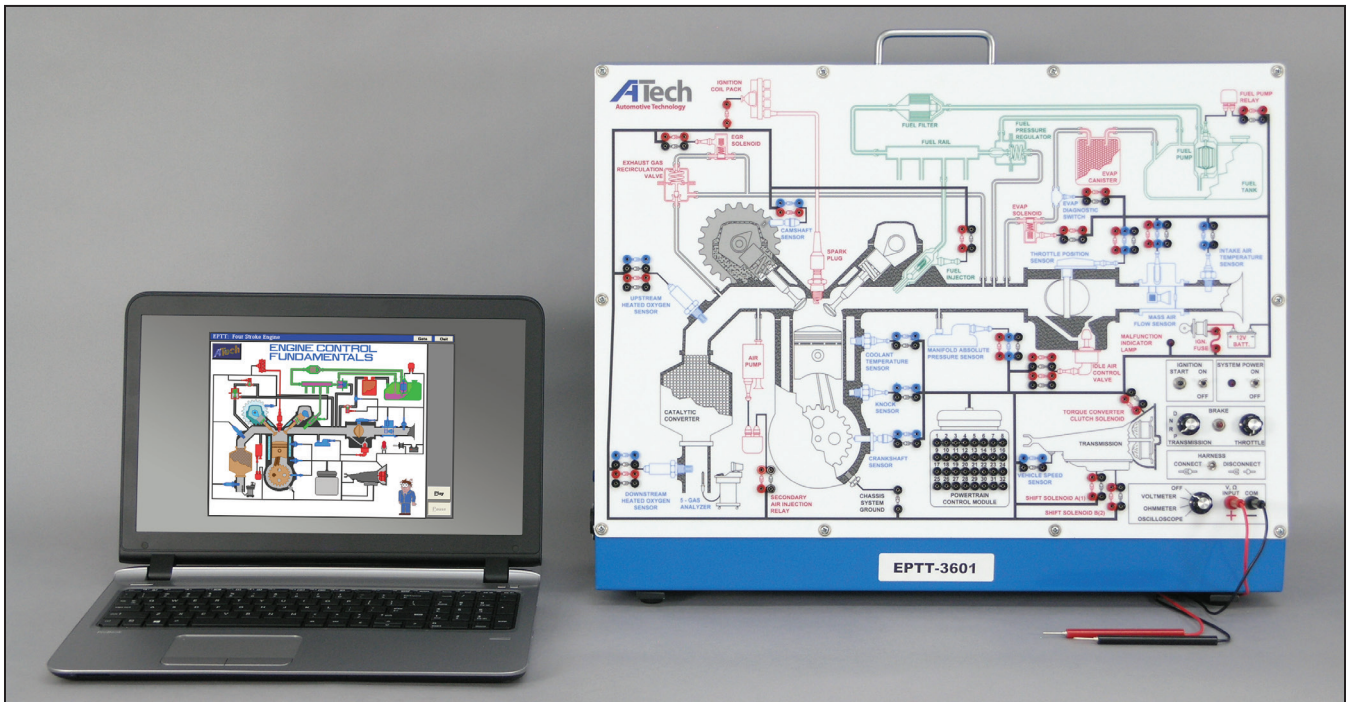

Computer-Based Programs

The #1 provider of Engine Performance Trainers offers computer-based simulation. A-Tech's automotive fundamental programs harness the power of computers to enhance the learning experience with animations of important concepts. Hands-on activities provide need-to-know reinforcement while computer-controlled diagnosis provides troubleshooting practice and competency testing. Keeps students highly motivated.

Engine Performance Troubleshooting Trainer Model 3601

The automotive fundamental programs include the Engine Performance Troubleshooting Trainer (Model 3601). This platform will support Models 3610, 3620 and 3630 computer-based courses and provides students with hands-on reinforcement.

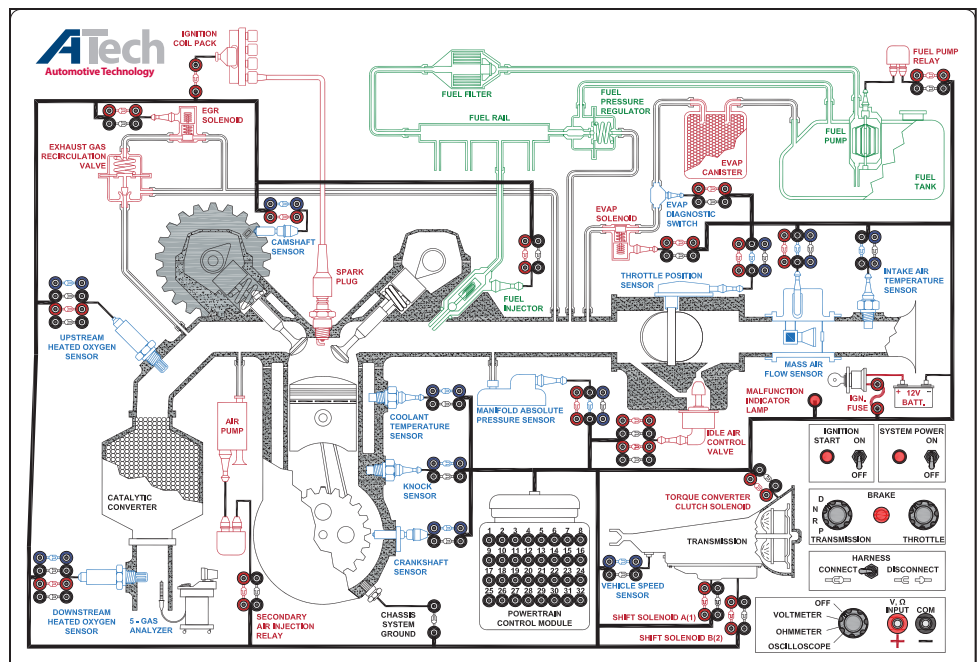

Computer-Based Instruction

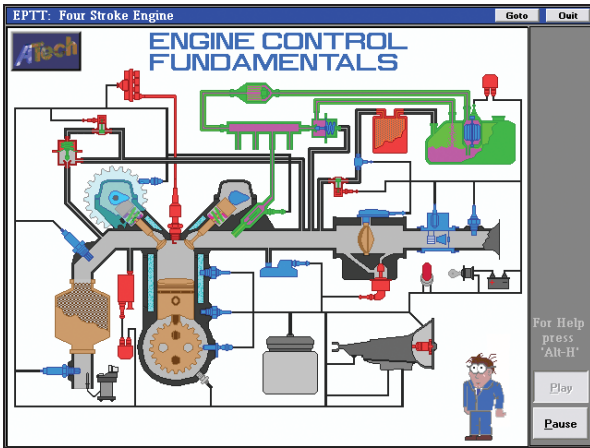

Engine Control Fundamentals Model 3610

This program consists of 21 student activities with more than 60 animations designed to present the fundamentals of engine control components. Includes hands-on digital voltmeter and ohmmeter use.

Engine Control Systems Operation Model 3620

This program consists of 14 student activities with more than 60 animations designed to present closed loop emission control systems. Includes hands-on voltmeter and oscilloscope usage.

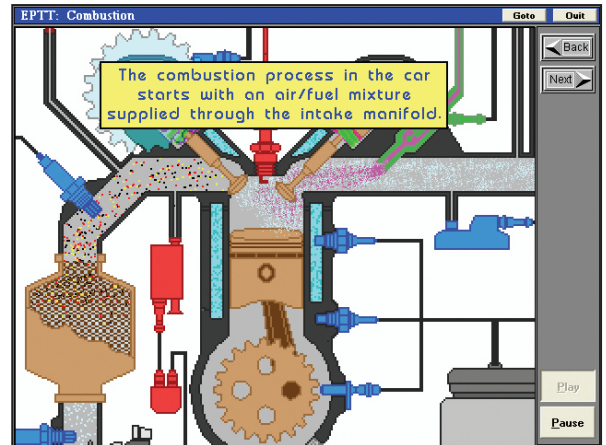

Engine Control Diagnostic Fundamentals Model 3630

This program consists of 16 student activities with more than 45 animations. Includes five automotive circuits to troubleshoot (Fuel Pump Relay, ECT, Fuel Injector, IAT, & TPS) with more than 60 faults. Includes instructor fault insertion capabilities.

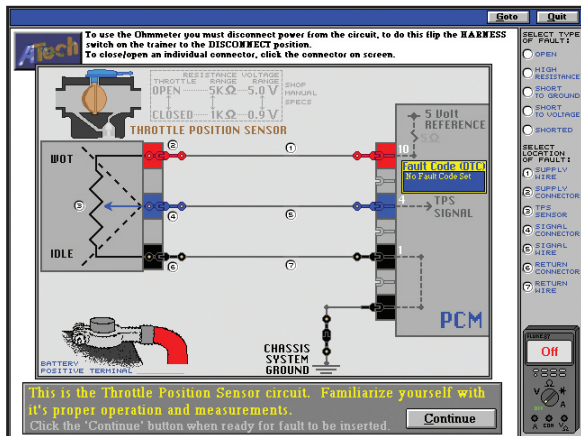

Student Record Keeping

All programs provide student record keeping. Each student is assigned a student identification (ID) number and password. The student's performance is recorded in their file as the student proceeds through the program.

Classroom Management

Each program includes an Classroom Management Program (CMP). With menu selections from the CMP, the student USB drive is prepared and records can be accumulated and transferred to the instructor's computer. Centralized storage of student records over a Microsoft™ network is also available. Program includes remote fault insertion capability. Remote faulting can't be used when using a student USB.

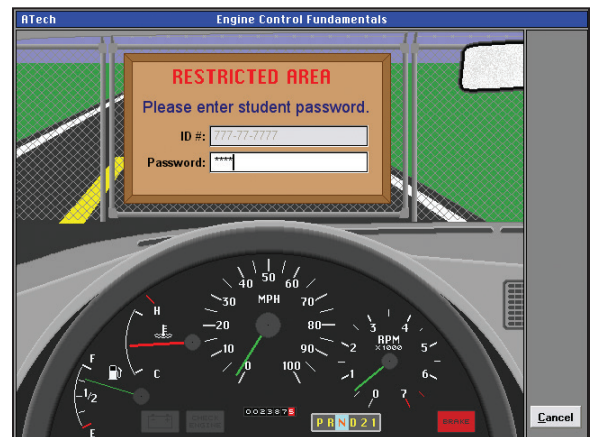

Computer-Based Instruction

Computer-Based Troubleshooting Skill Development ATech Model 3631

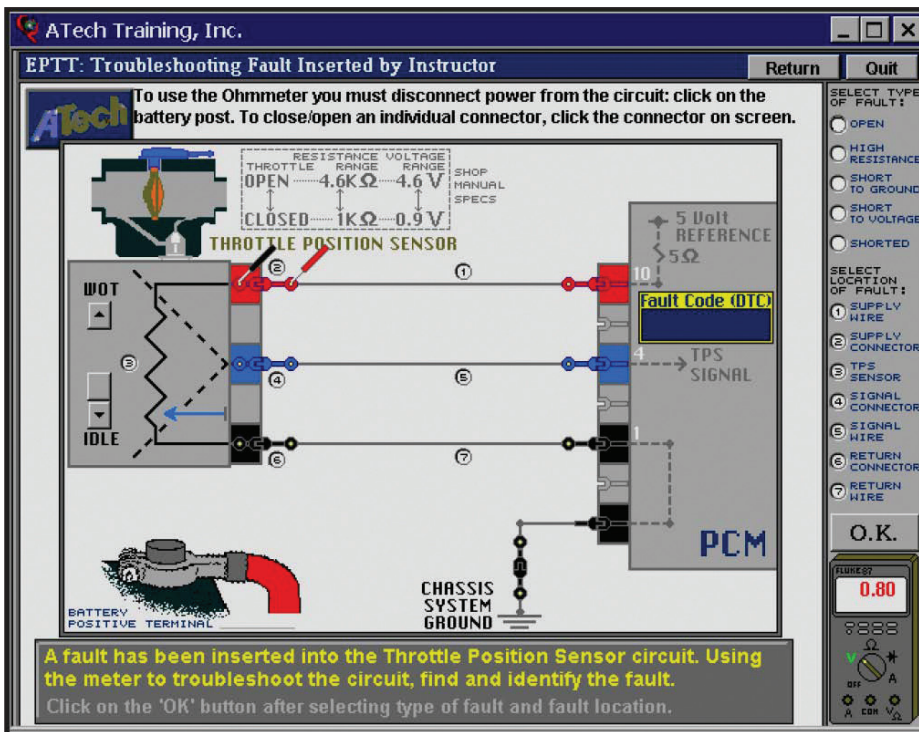

- Independent student practice
 - » no instructor intervention required
- Selection from one of five circuits for troubleshooting:
 - » Throttle Position Sensor
 - » Fuel Pump and Relay
 - » Fuel Injector
 - » Engine Coolant Temperature Sensor
 - » Intake Air Temperature Sensor
- Instructor can select circuit, fault type, and location
- Computer-controlled automatic fault insertion and random fault mode
- Network Version Available - model 3631N

- More than 60 real-world faults
- Multiple fault types:
 - » Opens in Wires and Connectors
 - » High Resistance in Wires and Connectors
 - » Short to Voltage
 - » Short to Ground
 - » Open Components
 - » Shorted Components
- Highly interactive:
 - » TPS circuit illustrates mechanical throttle valve operation
 - » Click to disconnect battery
 - » Slider adjusts TPS position

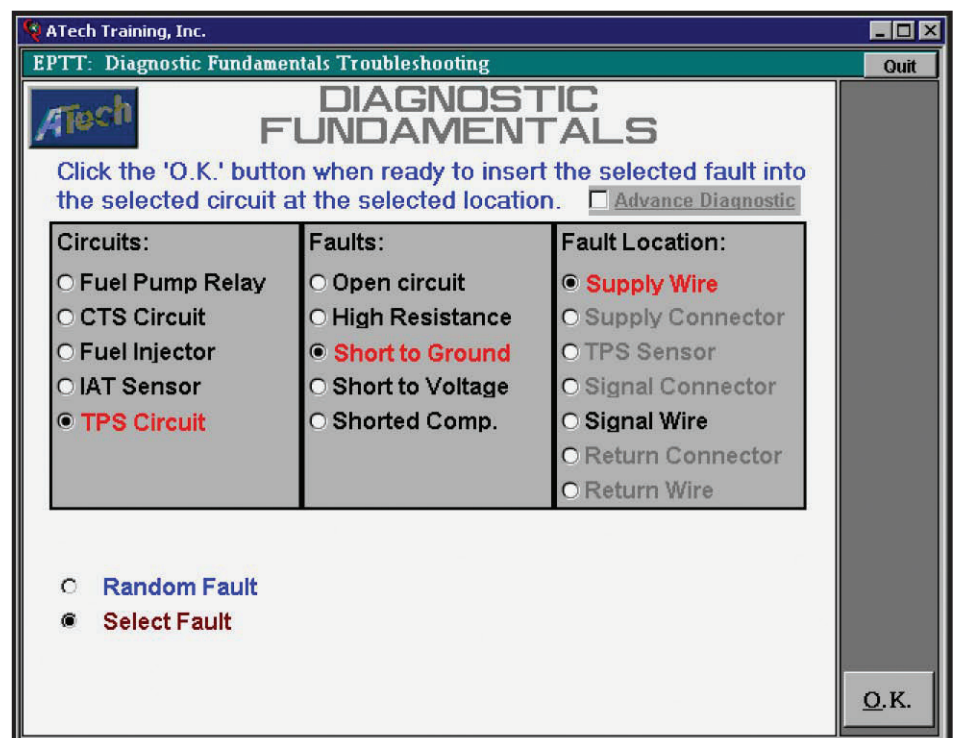

Computer-Based Instruction

Computer-Based Troubleshooting Skill Development ATech Model 3631

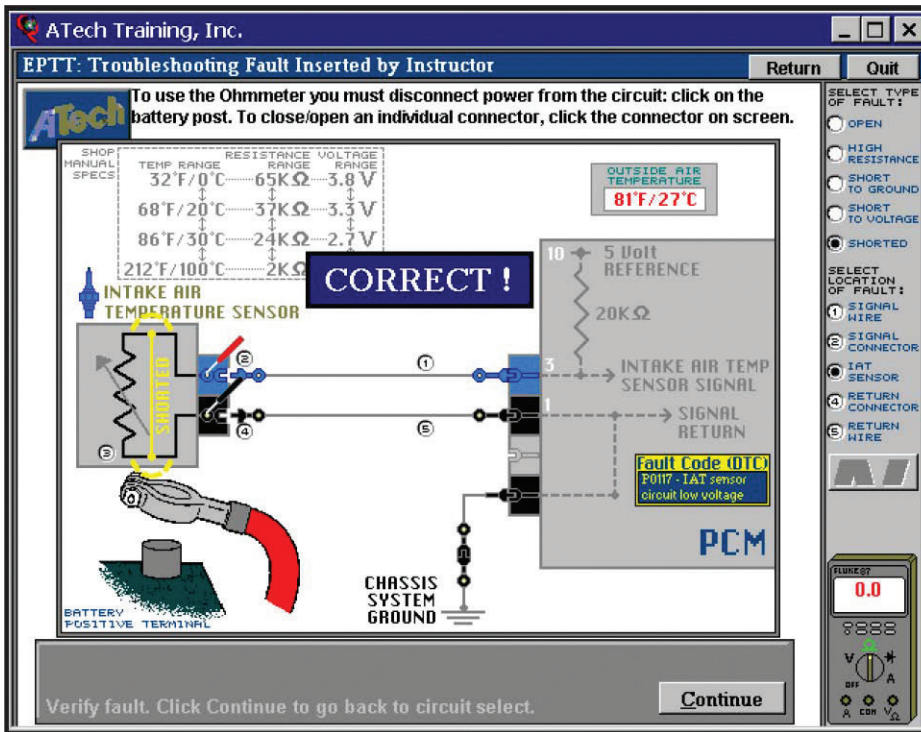

- Service manual specifications included on screen
- Temperature resistance relationships displayed on screen
- Built-in digital multimeter with interactive probes
- Real-world DTCs shown on scan tool readout screen
- Ohmmeter prompt given to disconnect circuit power
- Connectors can be disconnected
- Fuse can be removed and ground disconnected

- No repeated faults until all circuit faults have been initially completed
- Short-to-ground faults can blow fuses
- Two skill levels included:
 - » Training Mode: allows measurement across connector pins
 - » Advanced Mode: only allows back probing of connectors
- Probes automatically moved from disallowed connection points in Advanced Mode

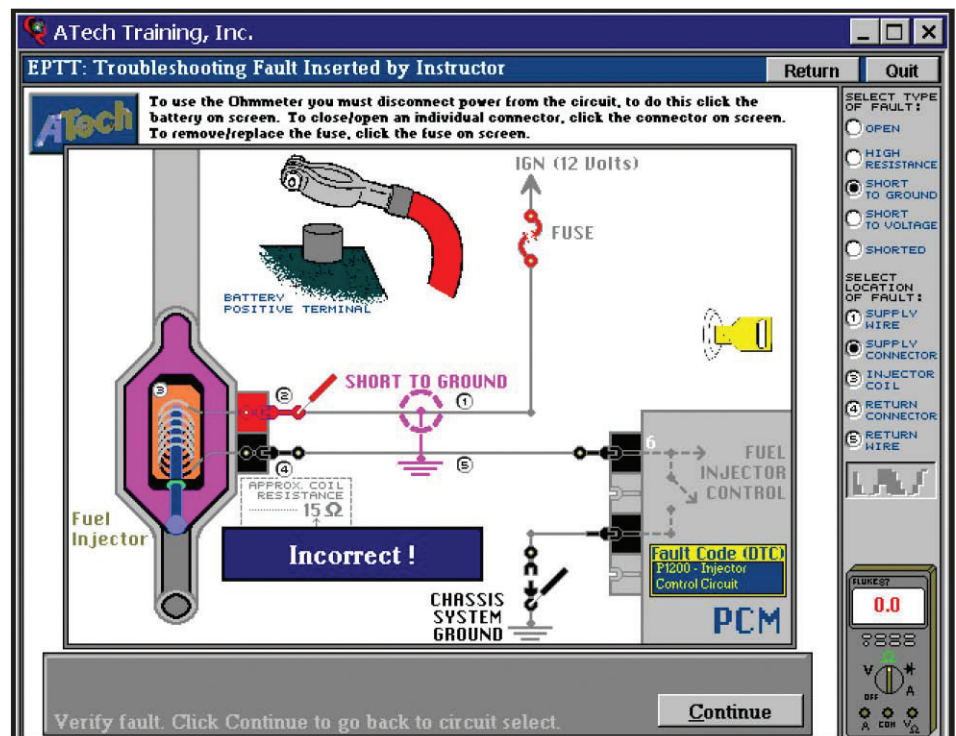

Computer-Based Instruction

GM S.E.T. Troubleshooting Trainer

Model 18002TT

- Quick setup for on-the-road training
- Fault insertion in individual or all student stations from instructor's computer
- Preselected faults will automatically be inserted in order of selection (when student completes one, next one is given)
- Instructor's computer displays student's answer, correct answer and stores results in student file

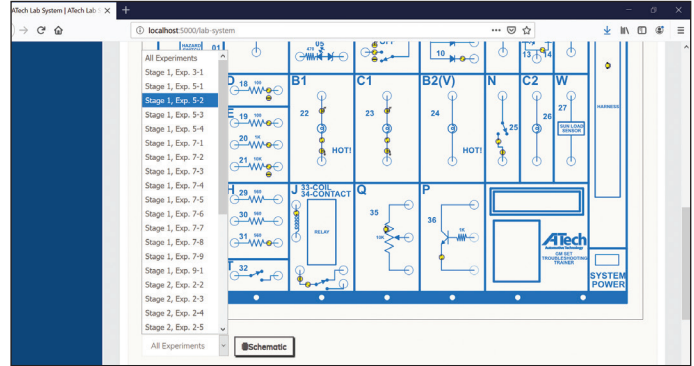

Fault Selection by S.E.T. Exercise Number

- ATech's "Schematic Based Fault Insertion" ©
- Fault Selection from list or schematic indicator
- On-screen indication of selected faults

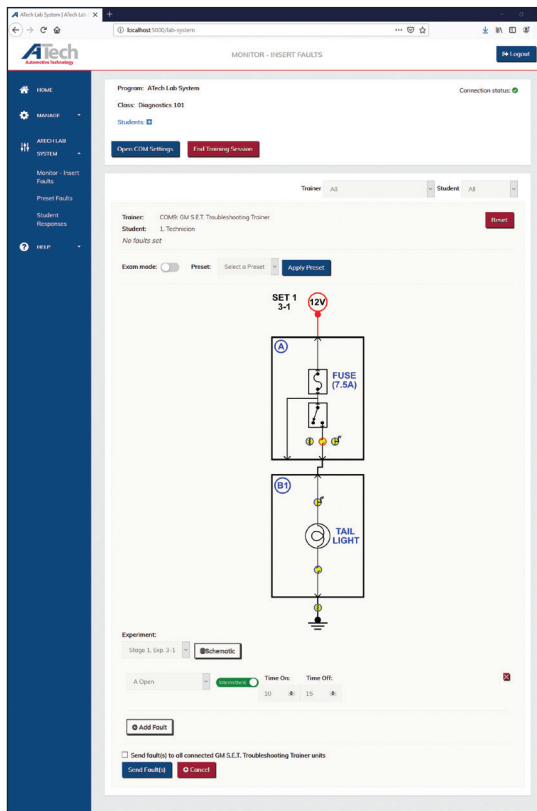

Intermittent Fault Time Adjustment

- Intermittent fault "On" and "Off" time adjustments
- "Build Your Own Circuit" capability
 - » Instructor can select from all faults
- Troubleshooting practice or exam mode capability
- Student results are saved in student file

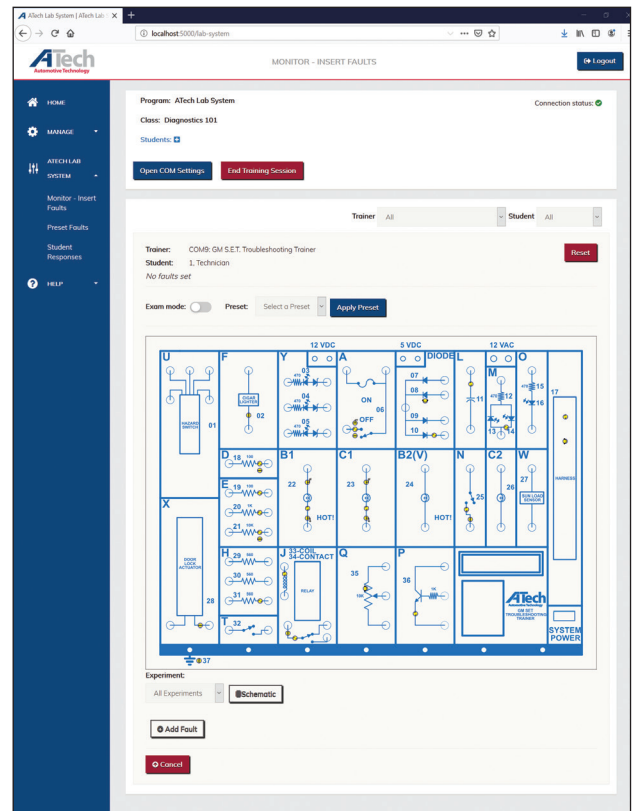

"Build Your Own Circuit" Fault Selection

Computer-Based Instruction

GM S.E.T. Virtual Trainer

This ATech software is a low-cost complement / alternative to the GM S.E.T. project board. The program provides a virtual simulation of the GM S.E.T. Trainer and the instructional resources to perform the experiments from the GM Electrical / Electronics Stage 1, Stage 2, and Stage 3 courses.

- Experiment circuit illustrated in schematic
- Operational schematic; i.e., switch operates on both pictorial circuit and schematic
- Operational schematic ties components to symbols

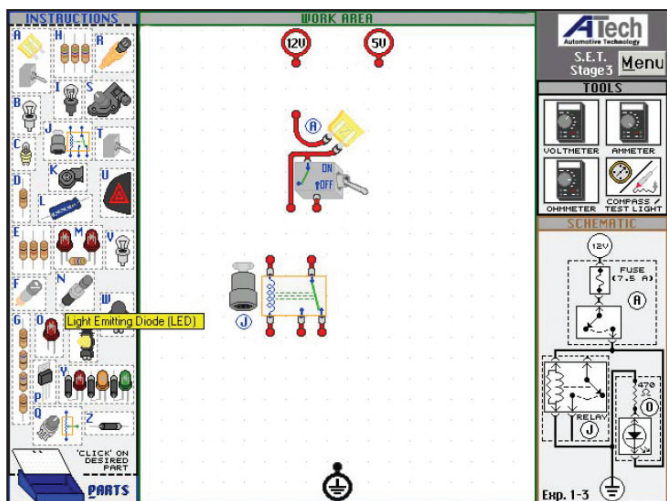

Circuit Selection by Experiment Number

- Submount / component selection from pictorials and module numbers
- Submount / component interactive placement by selecting and dragging to position
- Software checks for accurate submount / component selection

"I'd like to express my gratitude for all the assistance that your organization has provided. We have successfully installed the GM Virtual Trainers in our Automotive Computer Lab. This, of course, could not have been possible without the assistance of your staff. Our instructors love the product and have begun developing lesson plans to utilize the software this semester. We have seen a dramatic increase in the knowledge retention of our auto students since implementing a computer lab with automotive based software, and we look forward to enhancing their learning process with your products. Again, thank you for all your assistance through this matter"

Dept. of Information Technology
Trident Technical College

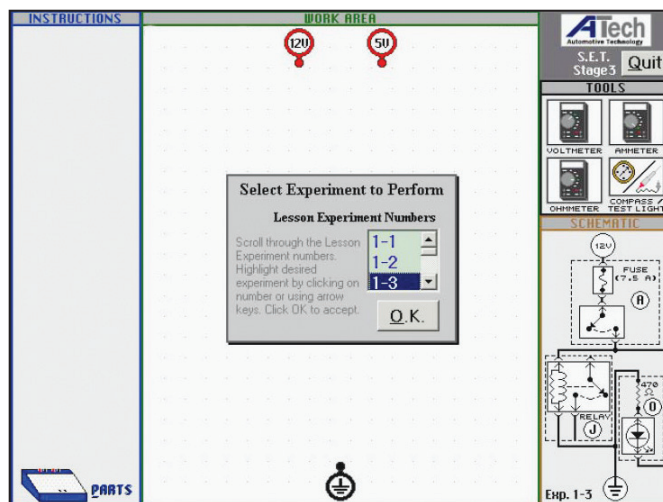

Submount Selection and Placement

- Interactive wiring of submounts
- Interactive relocation of wired submounts allows circuit reposition on breadboard
- Voltage measurements
- Resistance measurements
- Current measurements
- Simulated component operations

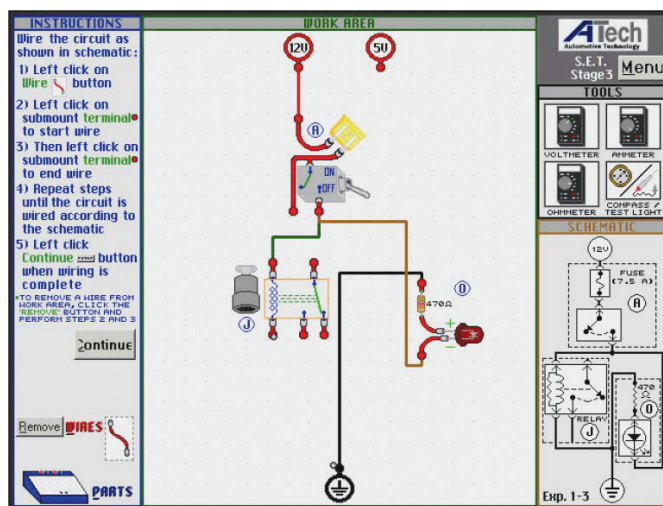

Interactive Wiring

Computer-Based Instruction

INSTRUCTIONS
Make measurements on circuit:
1) Left click on Switch to turn ON or OFF
2) Left click on either the red or black probe
3) To place probe, left click on desired terminal
4) Repeat steps 2 & 3 for other probe
5) Read Meter Display for value
6) Drag probes for new measurement
7) Left click Tools title bar [TOOLS] to select another tool
8) Left click on Next button when finished with Exp.

Tools - Voltmeter
12.00 V

SCHEMATIC
Exp. 9-1

GM S.E.T. Virtual Trainer - Stage 1 Model 18002VT1

- Properties of Electricity
- Ohm's Law
- Series Circuits
- Parallel Circuits
- Series-Parallel Circuits
- Electromagnetic Induction
- Network Version Available - Model 18002VT1N

GM S.E.T. Virtual Trainer - Stage 2 Model 18002VT2

- Automotive Electrical Components
- Solid State Components
- Vehicle Systems
- Network Version Available - Model 18002VT2N

INSTRUCTIONS
Make measurements on circuit:
1) Left click on Switch to turn ON or OFF
2) Left click on either the red or black probe
3) To place probe, left click on desired terminal
4) Repeat steps 2 & 3 for other probe
5) Read Meter Display for value
6) Drag probes for new measurement
7) Left click Tools title bar [TOOLS] to select another tool
8) Left click on Next button when finished with Exp.

Tools - Voltmeter
0.13 V

SCHEMATIC
Exp. 3-4

GM S.E.T. Virtual Trainer - Stage 3 Model 18002VT3

- Computers
- Sensor Inputs
- Actuator Outputs
- Series-Parallel Circuits
- Network Version Available - Model 18002VT3N

INSTRUCTIONS
Make measurements on circuit:
1) Left click Remove Wire button
2) Click a wire's start and end terminals
3) Click on red probe, then click on terminal of removed wire
4) Click on black probe, then click on other terminal of removed wire
5) Read Meter
6) Left click Replace Wire button for new measurement
7) Left click Tools title bar [TOOLS] to select another tool
8) Left click on Next button when finished with Exp.

Tools - Ammeter
2.00 A

SCHEMATIC
Exp. 2-1

Network Solutions

Lab Integration

model 812C

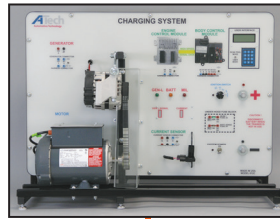

model 830C



model 5810TT

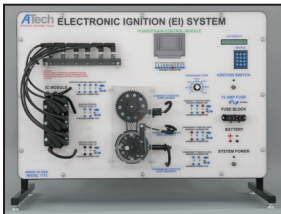

model 1772



model 840C



ALS



model 2652



model 1552



Instructor



Student

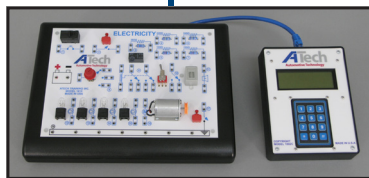

model 1810



model 3600

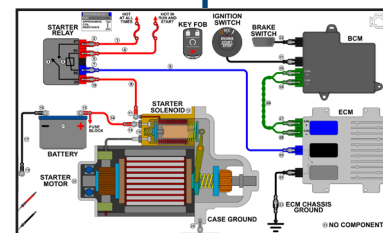

model 2815

Atech Trainers are Integrated

- Compatible with Microsoft™ Networks (no proprietary networking)
- Monitor student activities via Classroom Management Program (CMP)
- Multiple faults can be inserted into student training system
- Add new student training systems
- Assign individual student log-in identification
- Maintain student activity records

Network Solutions

Lab Integration

Fault Insertion Screens Examples

Atech 300 Series Trainers

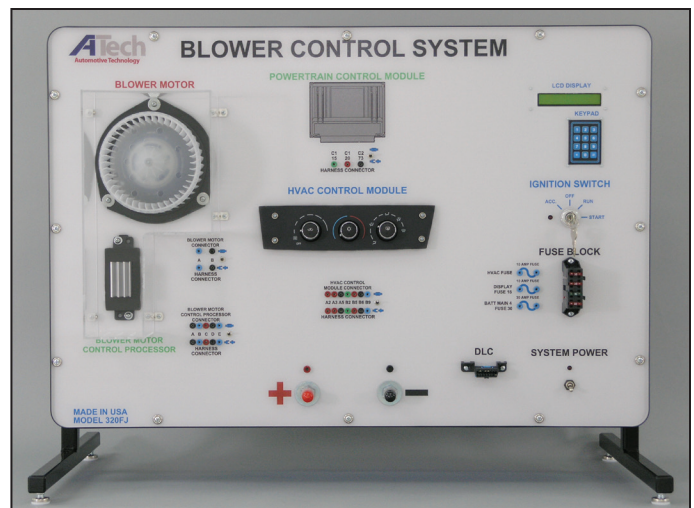
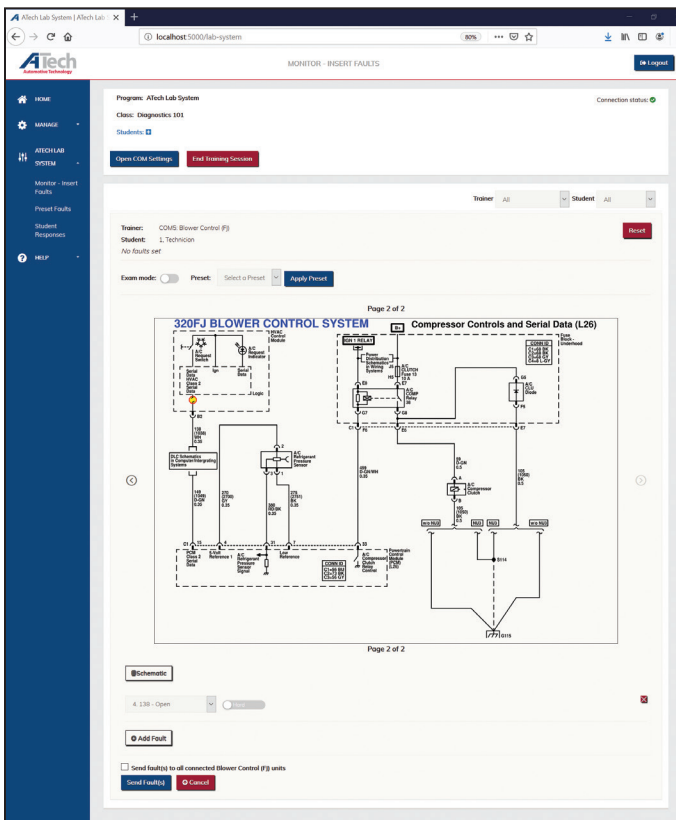
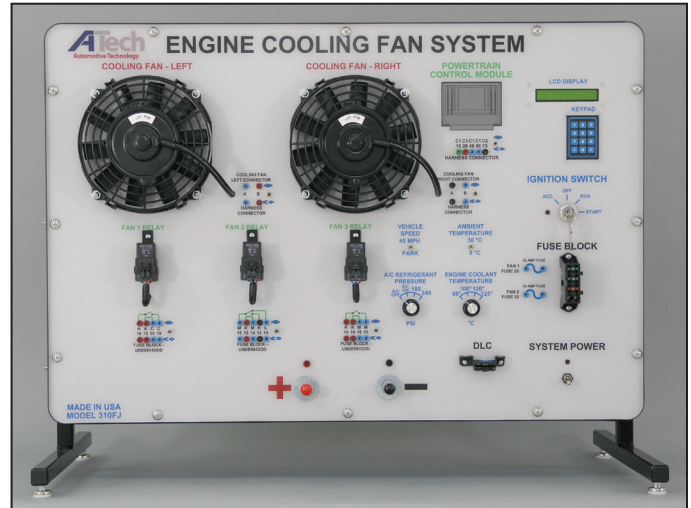
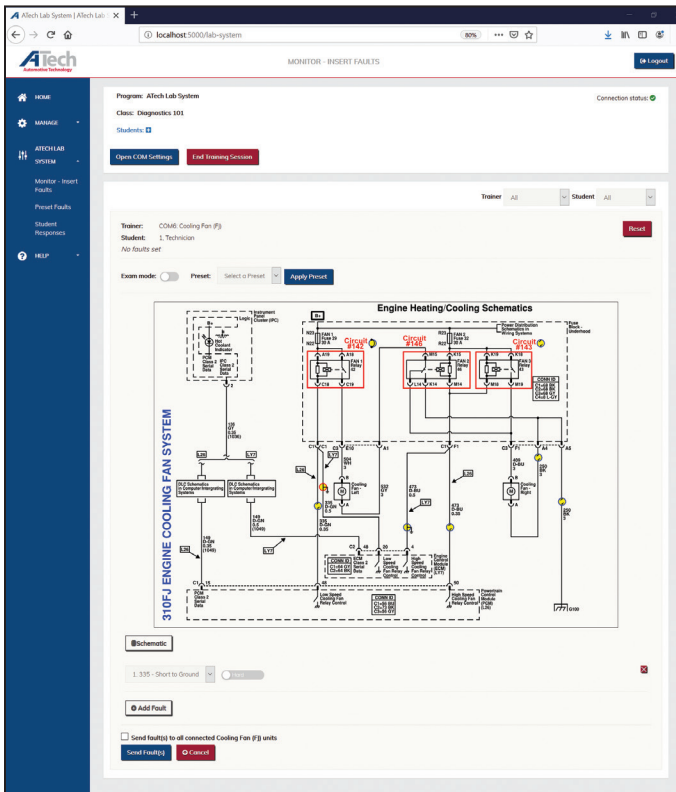

Network Solutions

Lab Integration

Fault Insertion Screens Examples

ATech 800 Series Trainers

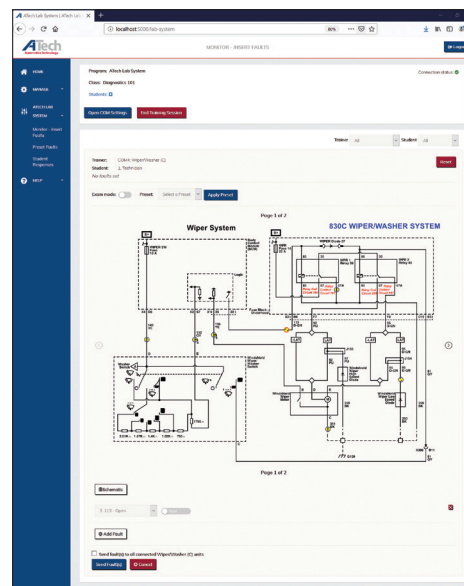
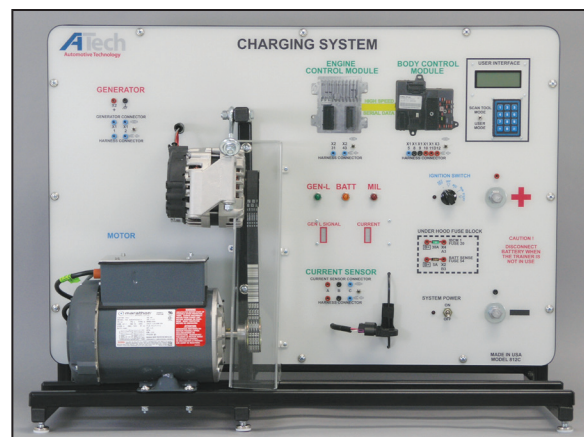
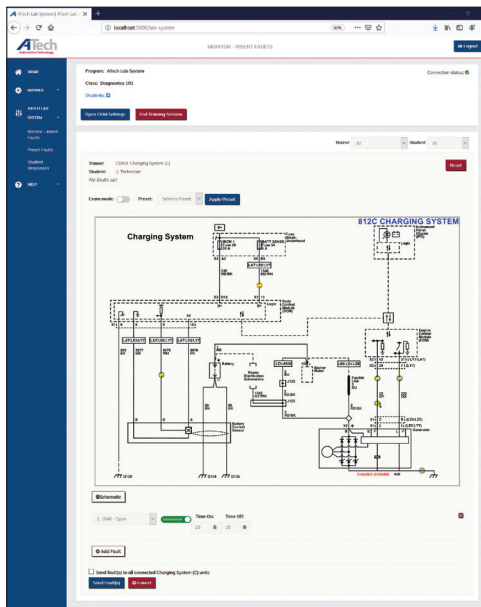
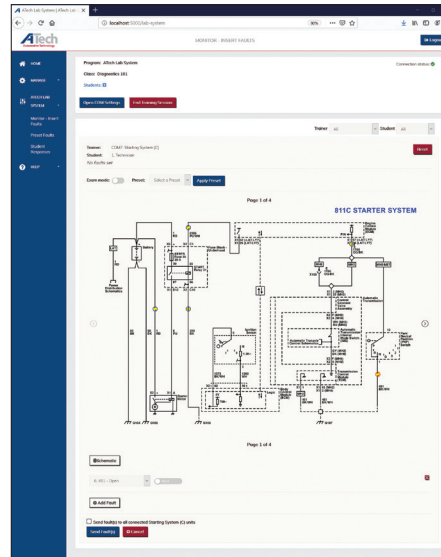
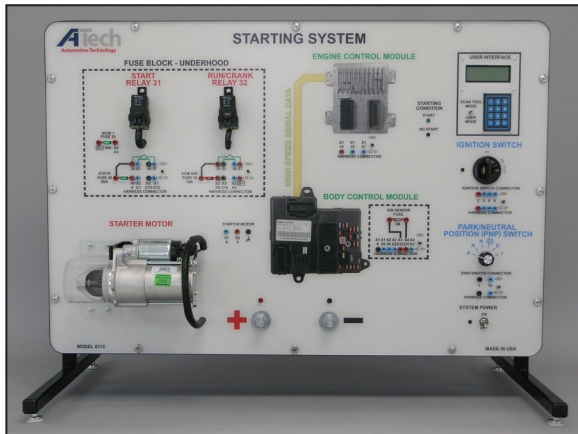

Network Solutions

Lab Integration

Fault Insertion Screens Examples

ATech 3600 Series Trainers

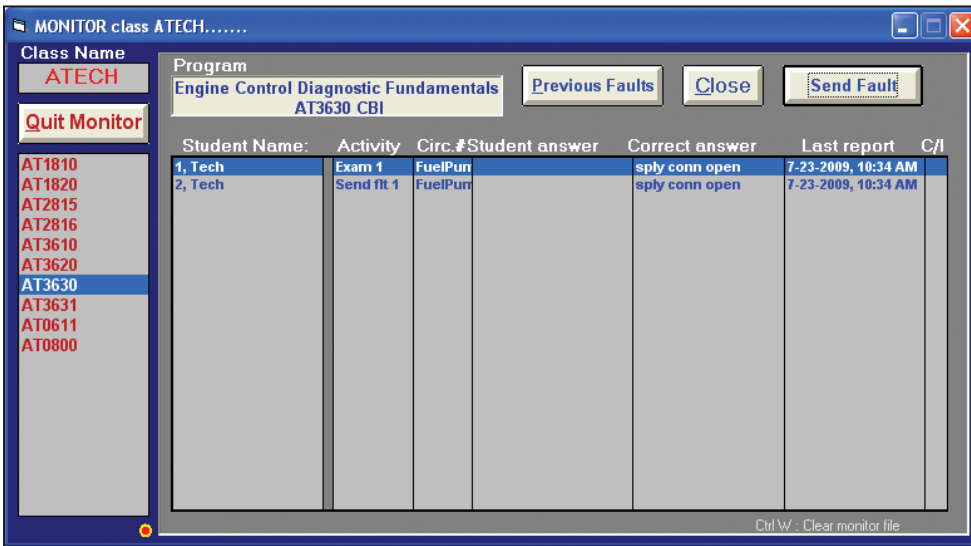

MONITOR class ATECH.....

Class Name: **ATECH**

Program: Engine Control Diagnostic Fundamentals
AT3630 CBI

Buttons: Previous Faults, Close, Send Fault

Student Name	Activity	Circ.#	Student answer	Correct answer	Last report	C/I
1, Tech	Exam 1	FuelPun		sply conn open	7-23-2009, 10:34 AM	
2, Tech	Send flt 1	FuelPun		sply conn open	7-23-2009, 10:34 AM	

Ctrl+W : Clear monitor file

Fault Monitoring Screen

ATech Engine Performance Troubleshooting Trainer (Model 3601)

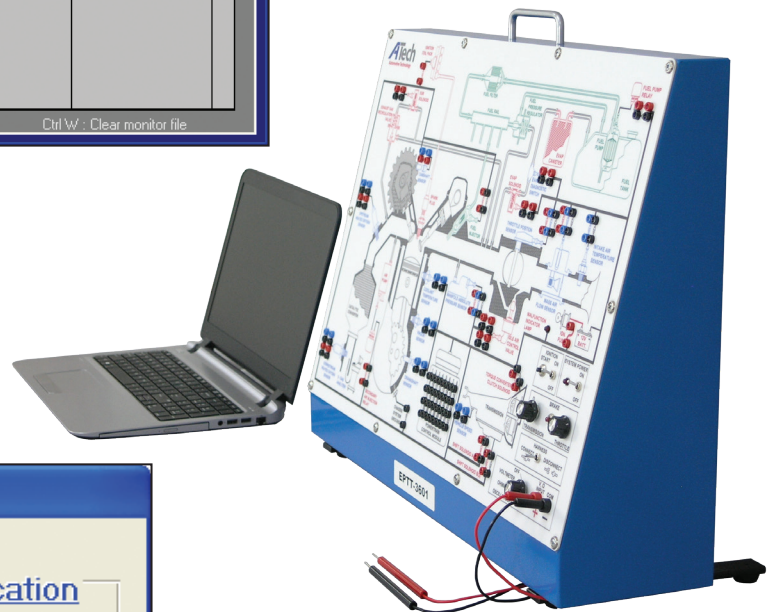

Fault Insertion Screen for Engine Control Diagnostic Fundamentals (Model 3601)

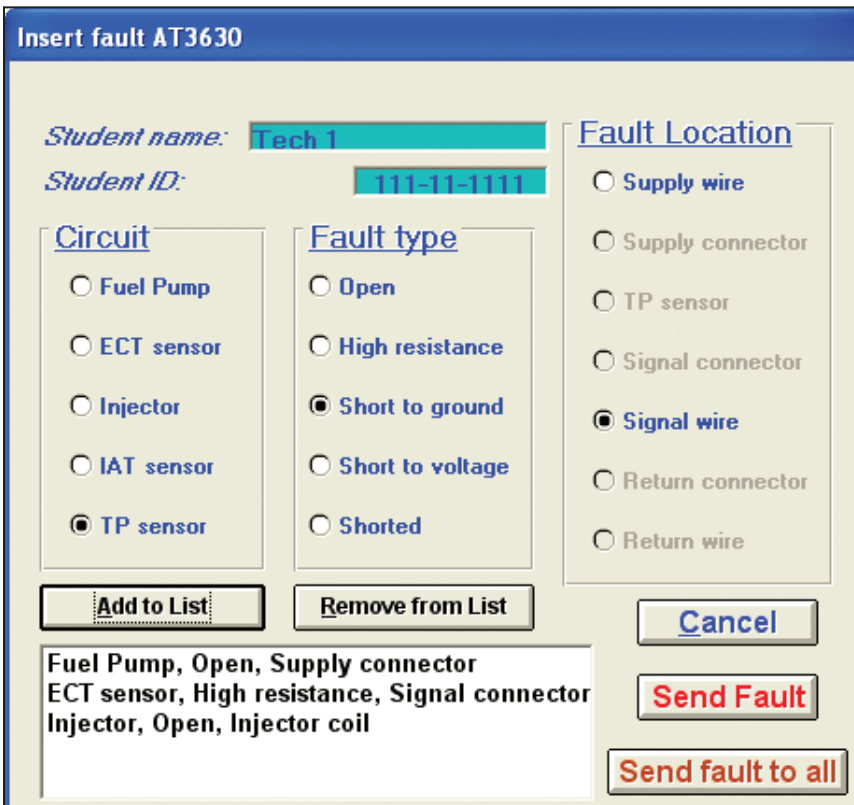

Insert fault AT3630

Student name: **Tech 1**

Student ID: **111-11-1111**

Circuit

- Fuel Pump
- ECT sensor
- Injector
- IAT sensor
- TP sensor

Fault type

- Open
- High resistance
- Short to ground
- Short to voltage
- Shorted

Fault Location

- Supply wire
- Supply connector
- TP sensor
- Signal connector
- Signal wire
- Return connector
- Return wire

Buttons: Add to List, Remove from List, Cancel, Send Fault, Send fault to all

Fuel Pump, Open, Supply connector
ECT sensor, High resistance, Signal connector
Injector, Open, Injector coil

Network Solutions

Lab Integration

Fault Insertion Screens Examples

ATech 1800 Series Trainers

STUDENT RESPONSES

Export to XLS

Student ID	Student Name	Class	Date	Trainer	Experiment	Question	Answer
111111111	1, Technician	Diagnostics 101	08/22/2019 09:10 AM	1810		3, 1, Hard	3, 1, Hard
111111111	1, Technician	Diagnostics 101	08/22/2019 09:10 AM	1810		9, 2, Hard	9, 2, Hard
111111111	1, Technician	Diagnostics 101	08/22/2019 09:10 AM	1810		16, 2, Hard	16, 3, Hard
111111111	1, Technician	Diagnostics 101	08/22/2019 09:10 AM	1810		17, 1, Hard	17, 1, Hard



1800 Series

Diagnostic Record Screen

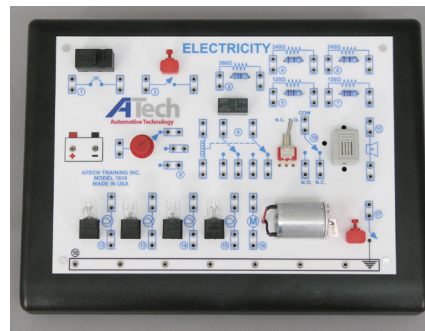

Fault Insertion Screen for Electricity (Model 1810)

Trainer: COMB: 1810 Electricity Trainer
 Student: 1, Technician
 No faults set

Exam mode: Preset: Select a Preset

All Experiments

- #01: 1810 Act 7 Series Circuit
- #02: 1810 Act 11 Parallel Circuit
- #03: 1810 Act 14 Series Parallel Circuit
- #04: 1810 Act 15 Trunk Release Circuit
- #05: 1810 Act 16 Horn Circuit
- #06: 1810 Act 17 Backup Lamp Circuit
- #07: 1810 Act 18 Tail Light Brake Light Circuit
- #08: 1810 Act 19 Starter Motor Circuit
- #09: 1810 Act 20 Turn Signal Side Marker Circuit
- #10: 1810 Act 21 Ignition Key Warning Circuit
- #11: 1810 Act 22 Cooling Fan Circuit
- #12: 1810 Act 23 Brake Warning Circuit
- #13: 1810 Act 24 Heater Blower Circuit
- #14: 1810 Act 25 Headlight Circuit
- #15: 1810 Act 26 Dome Light Circuit

Cutaways



Locking Differential / Limited-Slip Rear Axle Cutaway Model 126



- GM complete differential / axle
- Eaton limited-slip traction control system
- Carrier and pinion areas cutaway for easier viewing / instruction
- Powder-coated frame
- Includes casters to simplify movement

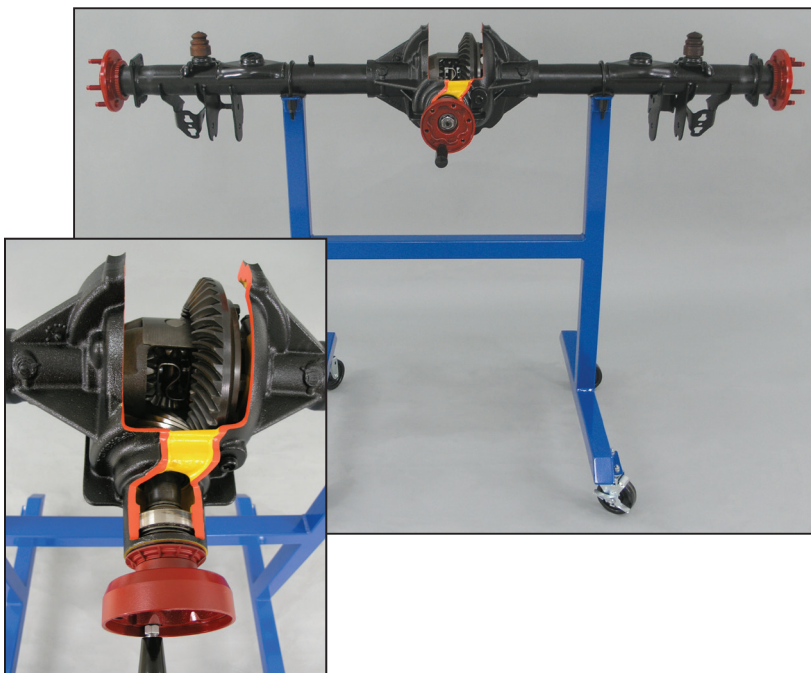

Limited-Slip Rear Axle Cutaway Model 127

- Recycled rear axle assembly
- Mobile stand
- Powder-coated frame

Cutaways

Manual Transmission (RWD) Cutaway Model 130

- Operating clutch and hand crank
- Recycled transmission
- Powder-coated frame

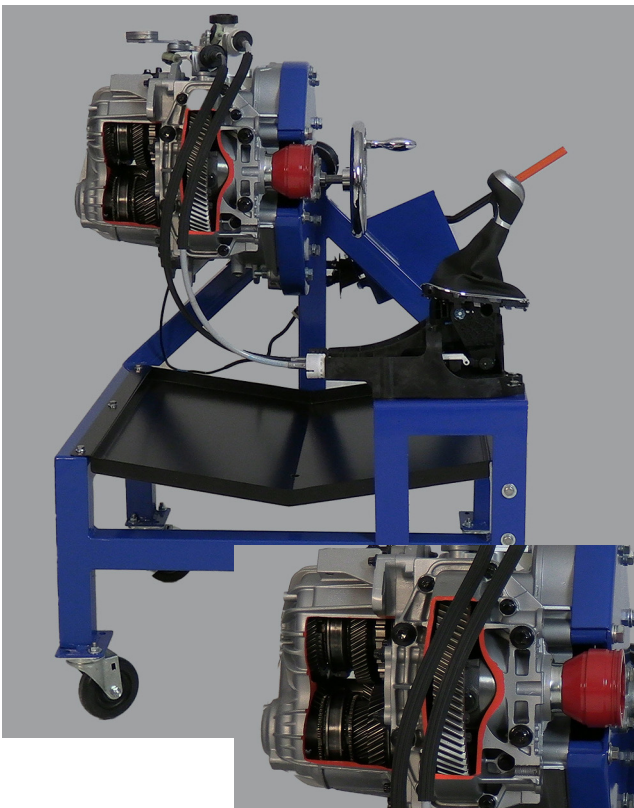
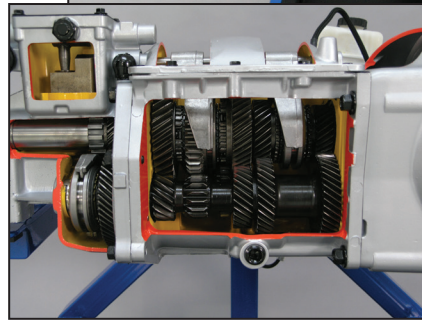
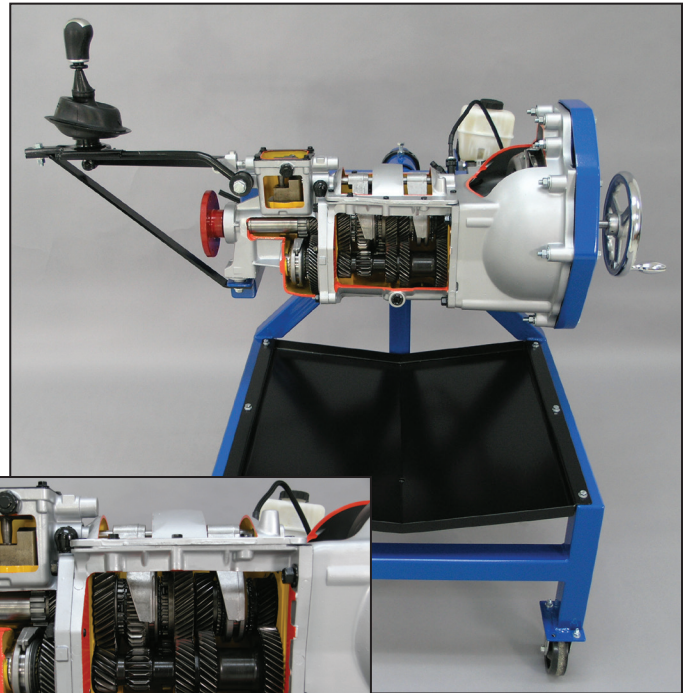

Manual Transaxle (FWD) Cutaway Model 140

GM • FORD

- Recycled late-model manual transaxle complete with clutch assembly and gear shift
- Includes handles to operate clutch and rotate gear shifts
- Cutaway to show internal components
- Powder-coated frame
- ASE task list and record keeping sheets

V5 Variable Displacement A/C Compressor Cutaway Model 382

The A/C Compressor Cutaway (Model 382) is a V5 Variable Displacement A/C Compressor. It includes a hand crank to rotate the compressor. The compressor is sectioned to show internal components and is mounted on a laminate base to provide stable display and use.

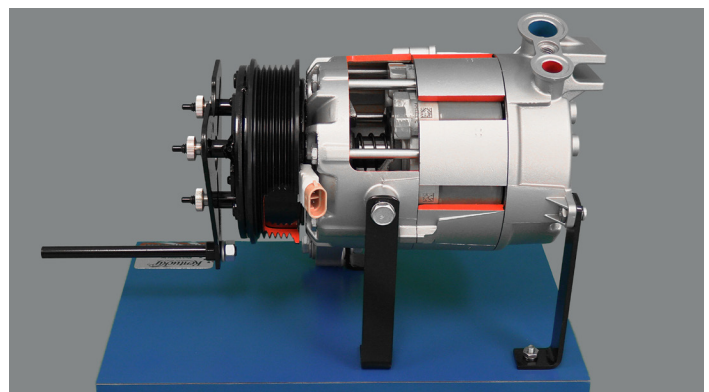

Cutaways

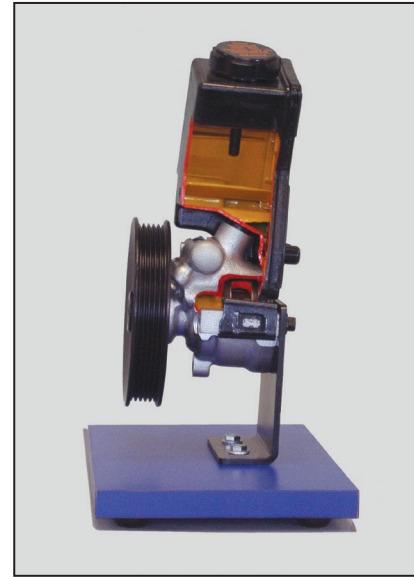
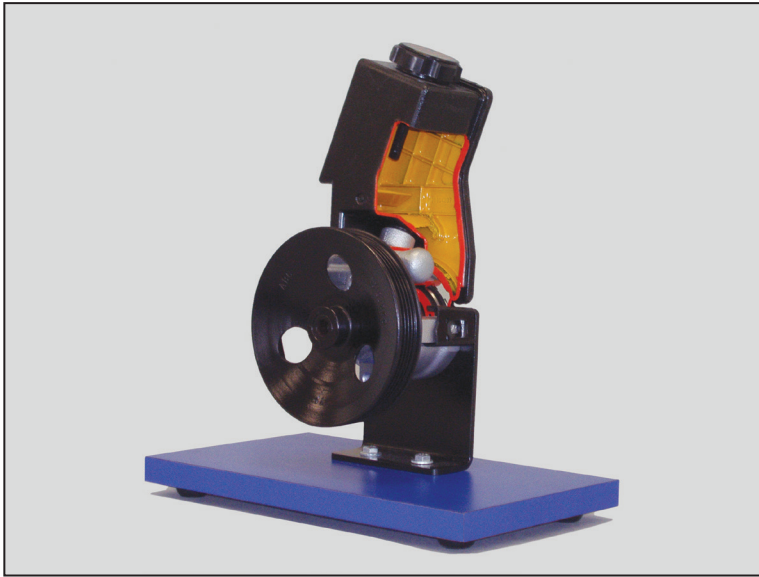

Power Steering Pump Cutaway Model 506

The Power Steering Pump Cutaway (Model 506) is a cutaway of an actual power steering pump that shows internal components allowing for demonstration of pulley operation.

Features:

- Late-model recycled power steering pump
- Hand crank
- Rotating power steering pump pulley
- Mounted on a laminate base

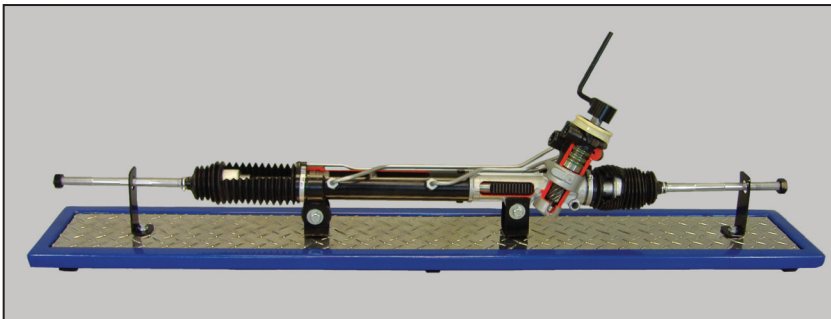

Power Rack and Pinion Cutaway Model 507

The Power Rack and Pinion Cutaway (Model 507) is a cutaway of an actual power rack and pinion that shows internal components, allowing demonstration of internal components.

Features:

- Late-model recycled power rack and pinion
- Hand crank
- Rotating steering gear
- Mounted on a diamond plate and powder-coated metal frame

Cutaways

Cylinder Powertrain Cutaway Model 680

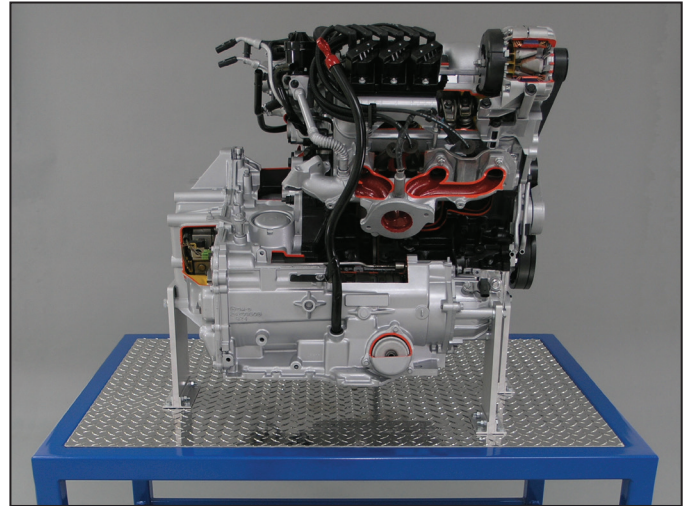
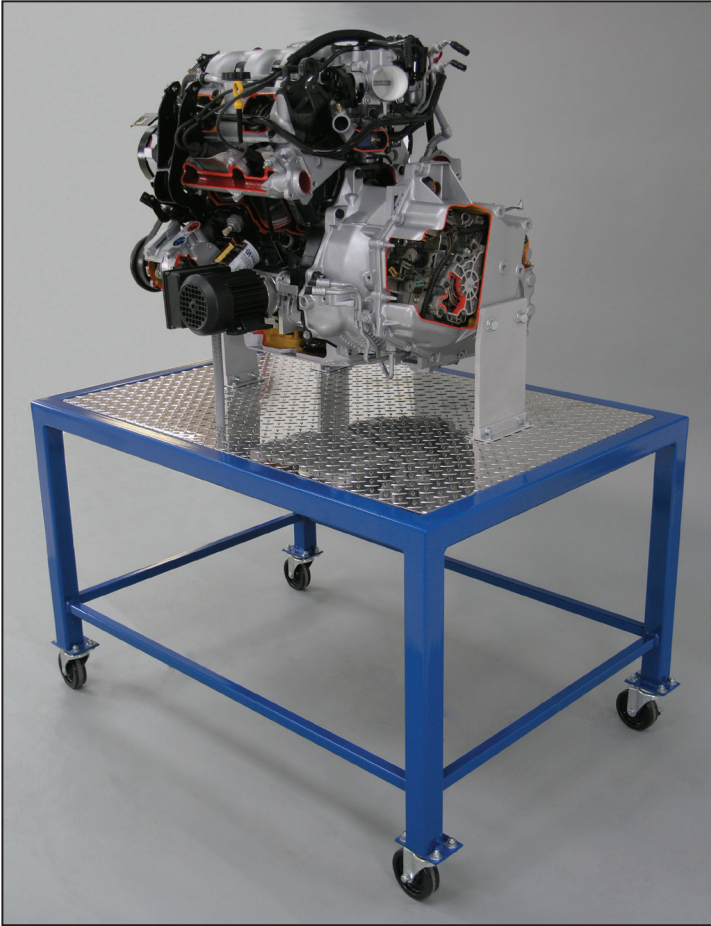

Side View

The Engine Cutaway Trainer (Model 680) is a complete GM engine with sections cutaway to expose the internal mechanical operating systems. Intake, exhaust, cooling, and lubrication systems are color coded to provide visual cues and allow for easy identification. This training unit includes an electric motor which rotates the engine at a low RPM to show the operation and interaction of the internal working components.

The Engine Cutaway Trainer uses an actual late-model engine and transaxle.

Cutaway Views:

- Engine
- Pistons
- Cam Operations
- Rings
- Crank Operations
- Oil Filter
- Oil Pick-up
- Intake Manifold
- Oil Pump
- Exhaust Manifold
- Coolant System
- Cylinder Walls
- Water Pump
- Fuel Rail
- Power Steering Pump
- Ignition
- A/C Compressor
- Transaxle
- EGR
- Flywheel
- Throttle Body
- Torque Converter
- Timing Chain
- Valve Body
- Intake Valve with Seat
- Clutches
- Exhaust Valve with Seat
- Bands
- Valves
- Band Servos
- Valve Springs
- Shift Interlock
- Rocker Arms
- Output Speed Shaft
- Push Rods
- VSS Sensor
- Connecting Rods
- Transaxle Filter

Cutaways

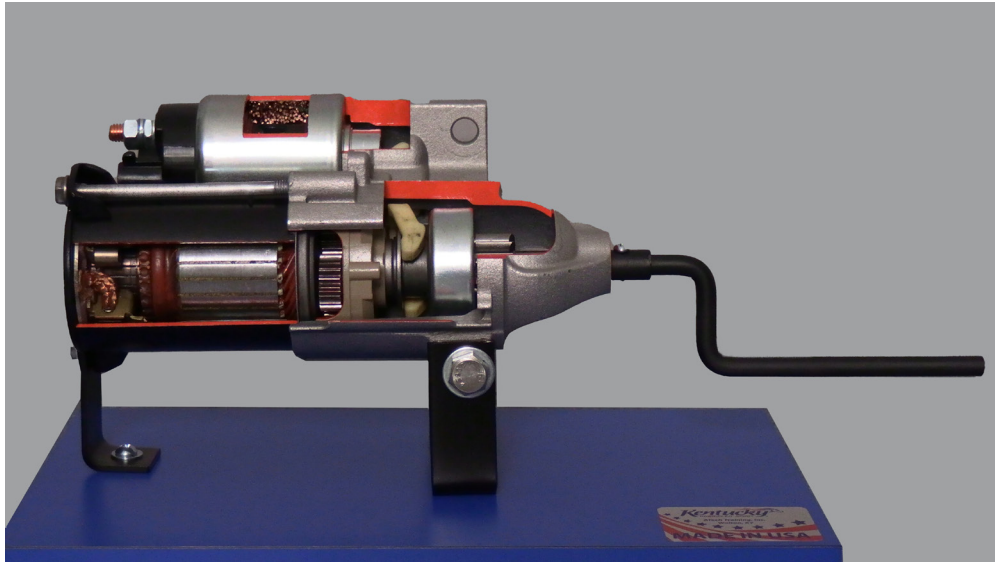

Starter Cutaway Model 813

The Starter Cutaway (Model 813) is a cutaway of an actual starter motor that shows internal components to demonstrate operation.

Features:

- Late-model remanufactured General Motors starter
- Hand crank
- Rotating starter
- Mounted on a laminate base

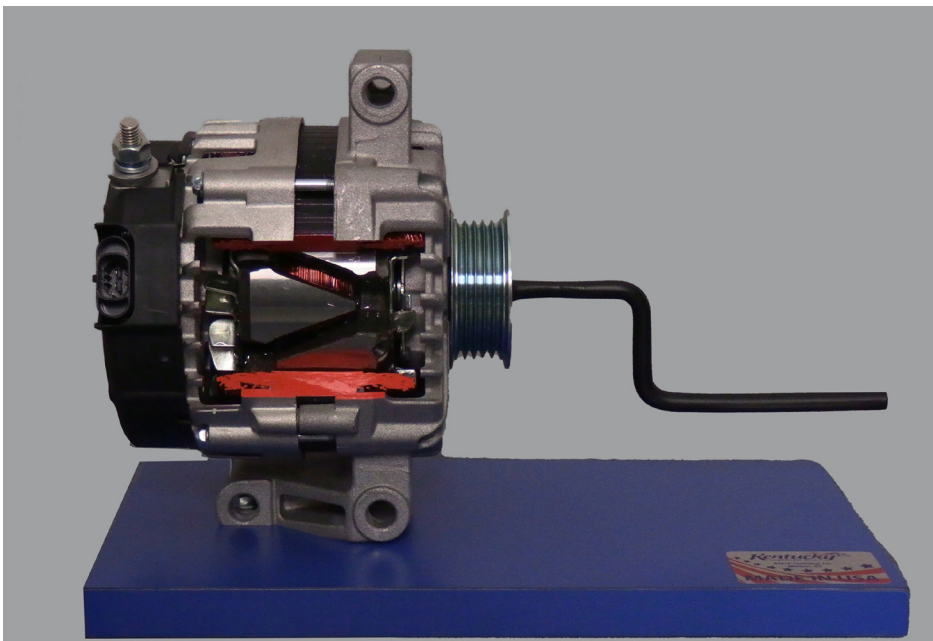

Alternator Cutaway Model 814

The Alternator Cutaway (Model 814) is a cutaway of an actual alternator that shows internal components to demonstrate alternator operation.

Features:

- Late-model remanufactured General Motors alternator
- Hand crank
- Rotating alternator
- Mounted on a laminate base

Cutaways

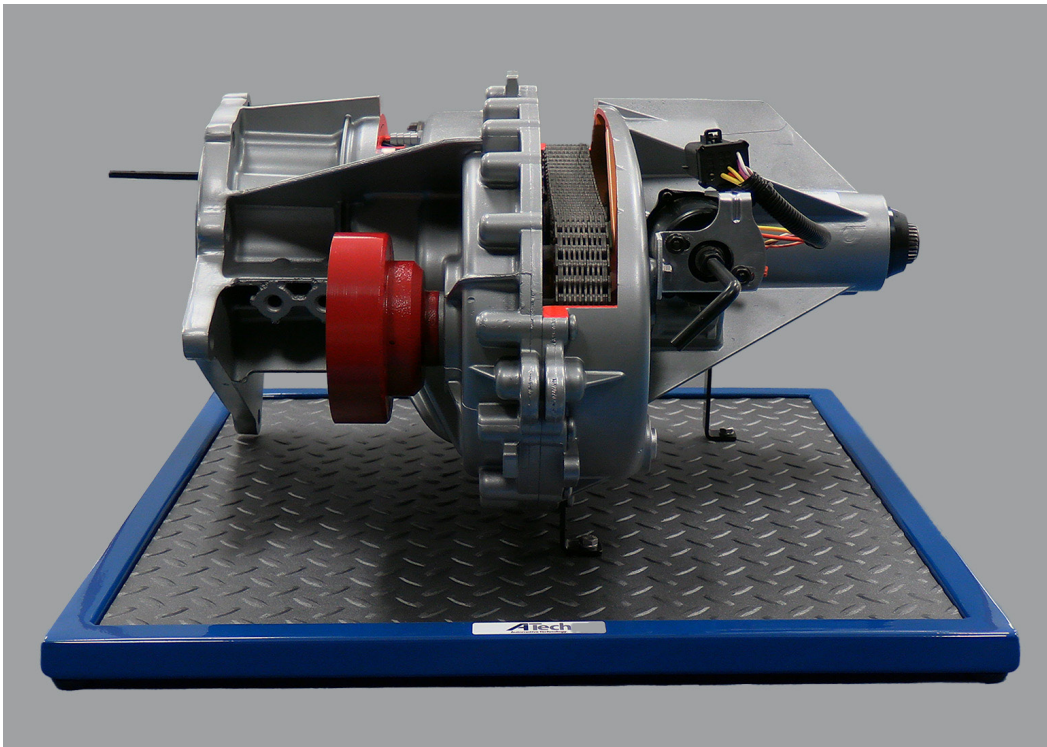

**Transfer Case Cutaway
(Showing Planetary Gear System) Model 1230**

GM • FORD

The Transfer Case Cutaway presents the viewing and operation of a transfer case. It provides hands-on experience to complete ASE Education Foundation Tasks.

- Actual late-model transfer case
- Case cutaway painted to enhance viewing
- Handle allows rotation of gears
- Mounted on a diamond plate and powder-coated metal frame

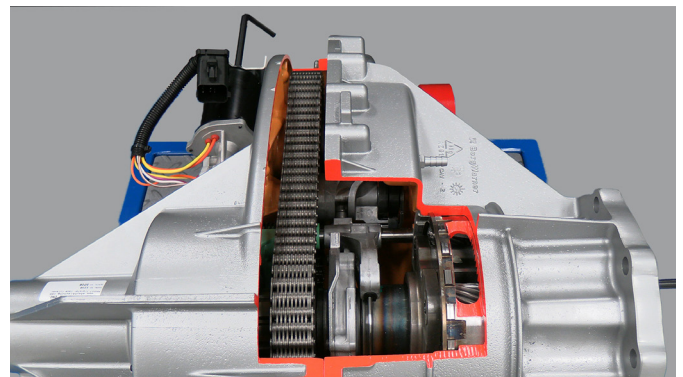

**Transfer Case (High Range Position)
(Model 1230)**

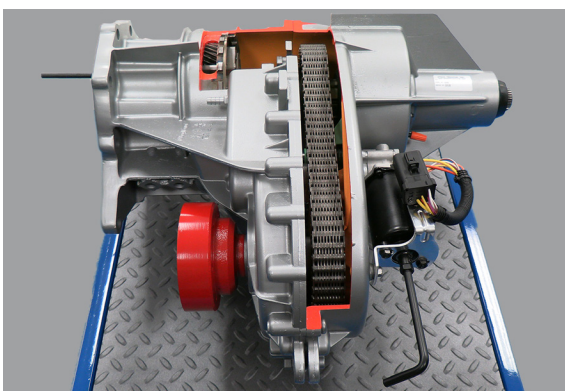

Cutaways/Models

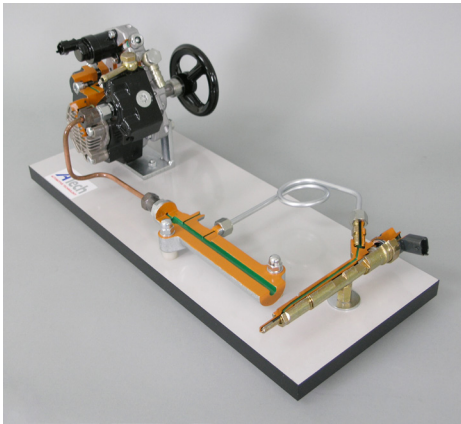

**Common Rail Diesel Cutaway
Model 10300**

This model shows an accurate cross-section of the high pressure (1300 bar) fuel system known as common rail. This circuit consists of a radial piston pressure pump, one delivery manifold, and an electro injector, all connected via high pressure hoses.

Features:

- Radial Piston Pressure Pump
- Delivery Manifold
- Electro Injector
- High Pressure Hoses
- Hand Crank
- Mounted on a Laminate Base



**Planetary Gear
Model ART 1069**

This model shows very clearly and instructively the operating system of a planetary gear, and the available ratio possibilities. Topical, as every automatic transmission, and numerous other components, contain planetary gears.

Features:

- Sliding Shifter
- Sun Gear Control Knob
- Carrier Gear Controller
- Ring Gear Controller
- Mounted on a Laminate Base
- Instructions for Operation



**Briggs & Stratton Small
Engine Cutaway
Model XR950**

Briggs & Stratton utility engine 208 cc:

- Aids in developing real-world system skills and knowledge
- Performs the following tasks:
 - » Valve Lash Adjustment
 - » Cam Shaft Timing
 - » Crank Shaft Timing
 - » Air Fuel Ratio
 - » Carburetor Adjustment
- Cutaway to expose:
 - » Magneto / Coil
 - » Spark Plug
 - » Low Oil Sensor
 - » Fuel Tank
 - » Filter
 - » Exhaust
- Performs actual service manual diagnostic procedures
- Powder-coated frame mounted on casters for ease of mobility

Contact ATech Training, Inc. for availability and pricing

ATech Training, Inc

sales@atechtraining.com ♦ 1.888.738.9924

Page 85

Accessories



Optional Floor Model Legs Model TFMJ

- Engine Cooling Fan System - 310FJ
- Blower Control System - 320FJ
- EVAP System - 640
- Starting System - 811C
- Lighting System - 821C
- Wiper / Washer System - 830C
- Power Window System - 840C
- Power Door Lock System - 850C
- Power Seat System - 860C
- Supplemental Inflatable Restraint System - 1552
- GM Electronic Ignition (EI) System 1772
- Ford Integrated Electronic Ignition System 1792

Optional Floor Model Legs
model TFMJ



Optional Floor Model Legs Model TFM

- Delco DBC7 ABS/TCS System - 1432
- GM (J1850) OBD II System - 2652
- GM (J1850) OBD II System - 2652DRY
- GMLAN Network System - 3802

Optional Floor Model Legs model TFM

Accessories

Optional Storage Case

**Electrical / PWM / Fault Trainer
Model 2210**

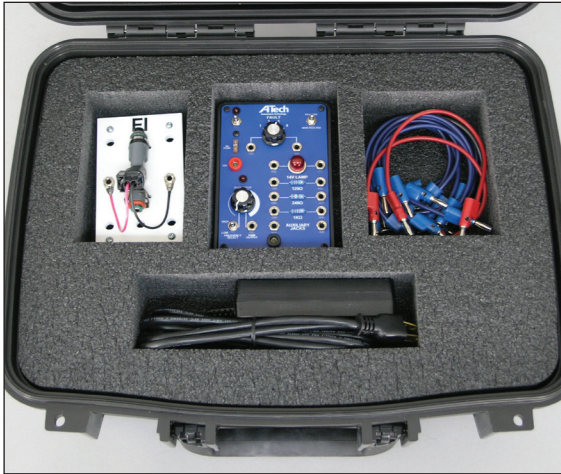

**Applied Electrical Trainer
Model 4810, 4820, 1810, 1820, 1830**

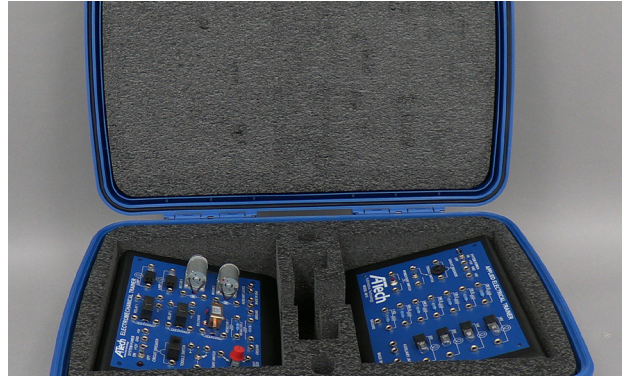

Maintenance and Light Repair (MLR) Plan

	HOURS	WORKSTATIONS
Phase 1 Electrical / Electronics	120	20
Phase 2 Electrical / Electronics	150	12
Basic Brakes	70	1
Basic Engine Performance	65	12
Basic Suspension and Steering	75	1
Basic Heating and Air Conditioning	25	3
Engine Repair	120	2
YEAR 1 TOTAL	625	51
	HOURS	WORKSTATIONS
Advanced Brakes	40	1
Advanced Engine Performance - Powertrain Controls	40	1
Advanced Engine Performance - Emissions	140	2
Advanced Ignition	15	1
Advanced Suspension and Steering	25	1
Advanced Heating and Air Conditioning	70	1
Automatic Transmission and Transaxle	30	2
Manual Drivetrain and Axles	70	3
YEAR 2 TOTAL	430	12
Contact an ATech Representative for pricing and trainer breakdown - Plan Binders are available!		
TOTAL	1055	63

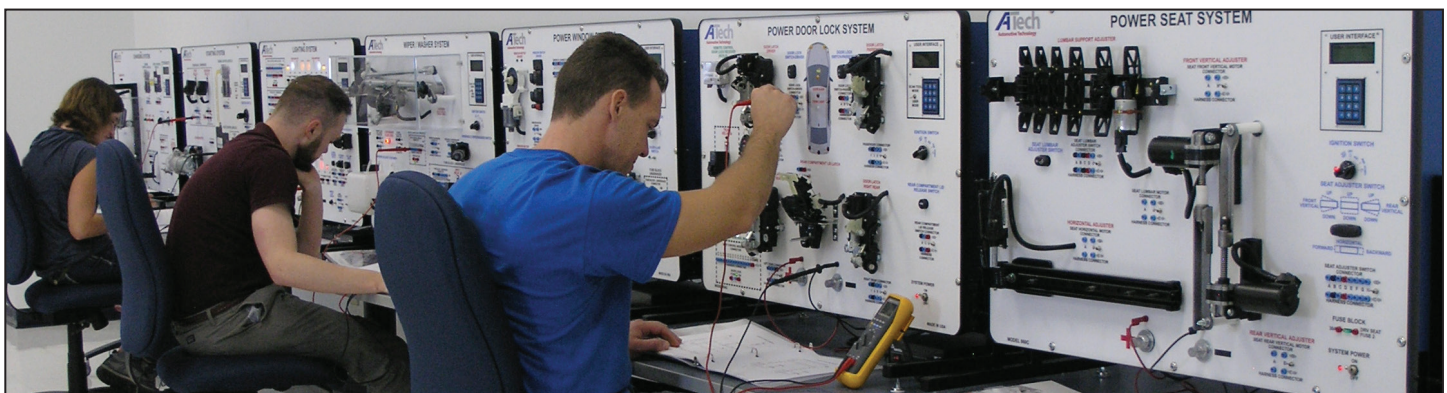



Automobile Service Technology (AST) / Master Automobile Service Technology (MAST) Plan

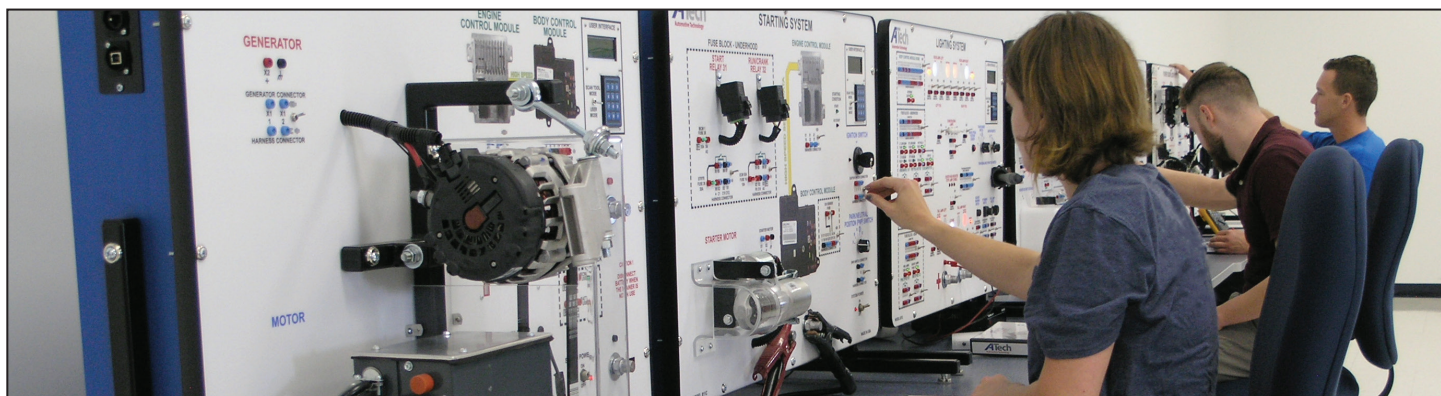

	HOURS	WORKSTATIONS
Phase 1 Electrical / Electronics	120	20
Phase 2 Electrical / Electronics	150	12
Basic Brakes	70	1
Basic Engine Performance	65	13
Basic Suspension and Steering	75	1
Basic Heating and Air Conditioning	25	3
Engine Repair	120	5
YEAR 1 TOTAL	625	55
	HOURS	WORKSTATIONS
Advanced Brakes	40	1
Advanced Engine Performance - Powertrain Controls	40	1
Advanced Engine Performance - Emissions	300	4
Advanced Ignition	30	2
Advanced Suspension and Steering	25	1
Advanced Heating and Air Conditioning	70	1
Automatic Transmission and Transaxle	70	4
Manual Drive Train and Axles	85	4
YEAR 2 TOTAL	660	18
Contact an ATech Representative for pricing and trainer breakdown - Plan Binders are available!		
TOTAL	1285	73



Get Social With Us!

Stay up-to-date with all the latest information and resources.

atech_training  /ATechTraining  /atechtraining 

@ATechTraining  /company/atech-training-inc 

Atech Training is a Member of:



WOMEN
OWNED BUSINESS



**A Veteran
Owned and Operated
American Company**



**View Us On Your
Mobile Phone**
www.atechtraining.com

ATech
Training™



Atech Training, Inc.
12290 Chandler Drive • Walton, KY 41094
Toll Free: 1-888-738-9924
Phone: 859-485-7229 • Fax: 859-485-7299
E-mail: sales@atechtraining.com
Web Site: www.atechtraining.com